



ENDOS AC / ACP CE 0051
(120V version)



Service Manual

Revision history Manual code 6961902103

Rev.	Date	Page/s	Modification description
0	02.04.03	-	Document approval.
1	25.09.03	All	Remote timer version release. ETL certification. Spare Parts update. (Ref. RDM 5641, RDM 5644)
2	10.11.03	7, 8	Addition of "X-MIND" identification on main label. (Ref. RDM 5693)
3	26.03.04	8	Notify body change for CE mark. (Ref. RDM 5781)
4	15.03.05	8, 18, 72, 73	Editorial correction on Enabling/Disabling the "Ready" key. Modified the DP arm label. (Ref. RDM 5938, RDM 6052)
5	10.01.06	28	Dose linearity reference measurement time updated. (Ref. RDM 6164)
6	13.07.07	30, 31, 45, 104, 108, 110	Removed optional chemical screws. Added NOTE with indication that the device is supplied as unit to be installed permanently (EN60601-1 – paragraph 19). Spare Parts update. (Ref. RDM 6568, RDM 6620)
7	17.07.13	6, 8, 31, 34, from 39 to 43, 58, 59, 96, 98, 100	New scissor arm assembling procedure. Added note on spacer insertion during stand arm set assembling. Identification label update. Mains plug on mobile stand version no more supplied. Schematics and drawing update. Spare Parts update. (Ref. RDM 7302, RDM 7532, RDM 7710, RDM 7723, RDM 7763, RDM 7797)

THIS PAGE IS INTENTIONALLY LEFT BLANK

Contents

1. INTRODUCTION	1
1.1 Icons in the manual.....	1
2. SAFETY ASPECTS	2
2.1 Warnings	3
2.2 Protection from X-rays.....	4
2.3 Environmental risks and disposal	5
2.4 Symbols in use	6
3. DESCRIPTION	7
3.1 Identification labels	7
3.2 Functions, Models and Versions.....	9
3.2.1 Extension arm and scissors arm.....	9
3.2.2 Tubehead.....	9
3.2.3 Timer	10
3.3 Configurations.....	11
3.3.1 Standard configuration.....	11
3.3.2 Remote timer configuration	12
3.3.3 Mobile stand configuration	13
3.3.4 Remote X-ray button configuration	14
4. TECHNICAL DATA	15
4.1 Method for correcting exposure times.....	18
4.2 Method for measuring technical factors.....	20
4.3 Correct use of dosimeters to measure exposure times	21
4.4 Curves tube features	23
4.5 Reference standard.....	27
4.6 Overall dimensions	29
5. PRE-INSTALLATION	30
5.1 Mounting methods	30
5.2 Electric pre-setting	31
6. INSTALLATION	32
6.1 Wall installation	32
6.1.1 Timer set up (standard configuration)	33
6.1.2 Wall support set-up (Remote Timer configuration)	35
6.1.3 Timer set up (Remote Timer configuration).....	36
6.1.4 Assembling the mobile stand and timer installation.....	37
6.1.5 X-ray button	38
6.2 Assembling the scissors arm	39
6.2.1 Assembling the scissors arm (DP arm)	39
6.2.2 Assembling the stand arms set	43

6.3	Tubehead assembly	44
6.4	Installation of the optional parts.....	45
6.4.1	Counterplate.....	45
6.4.2	Remote X-ray button.....	46
6.4.3	Installation of chemical screws	47
6.5	Electrical connection	48
6.5.1	Electrical connection for standard versions.....	49
6.5.2	Electrical connection for versions equipped with Remote Timer	50
6.6	Final working tests	51
6.6.1	"ENDOS ACP" timer	51
6.6.2	"ENDOS AC" timer	54
7.	MAINTENANCE	56
7.1	Generalities	56
7.2	Arm adjustment.....	57
7.2.1	Adjusting the extension arm support frictioning mechanism	58
7.2.2	Adjusting the extension arm frictioning mechanism	59
7.2.3	Adjusting the balance scissors arm.....	60
8.	SET-UP	62
8.1	Display and modification of parameters.....	66
9.	ERROR MESSAGES AND TROUBLESHOOTING	76
9.1	Functional messages	77
9.2	Errors during start-up phase.....	80
9.3	Errors that can be reset during the start-up phase.....	82
9.4	Errors during X-ray exposure	83
9.5	Faults not signalled	84
9.5.1	The timer does not work.....	84
10.	REPLACING PARTS	87
10.1	Replacing the tubehead	87
10.2	Replacement timer boards	88
10.3	Replacing the keyboard	88
10.4	Replacing the scissors arm	88
11.	SCHEMATICS AND DRAWINGS	89
12.	SPARE PARTS	97
13.	FIXING TEMPLATES	109

This publication can only be reproduced, transmitted, transcribed or translated into any human or computer language with the written consent of Manufacturer.
This Manual in English is the original version.

1. INTRODUCTION

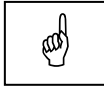

NOTE:

This manual is updated to the product status it is sold with, to guarantee the user an adequate reference for equipment use and any aspect connected with use safety. The manual may not reflect any product variation without impact on operating procedures and use safety.

The intraoral radiographic ENDOS AC/ACP, produces high quality intraoral X-rays, thanks to reduced exposure times and the small dimensions of the focal spot.

ENDOS AC/ACP is exclusively intended for the execution of intraoral X-rays.

The equipment has the following features:

- Very good quality X-rays pictures
- user friendly
- ergonomic design.

The equipment is controlled by a microprocessor that makes it possible to reproduce exposure times and is composed of the following parts:

- Timer: ENDOS AC or ENDOS ACP equipped with wall plate
- Extension arm (30 cm, 60 cm or 80 cm for wall version)
- Scissors arm (DP)
- Tubehead 70 kV 8 mA – X-ray tube with grid.

The purpose of this manual is to provide the user with instructions that will allow him to run the equipment safely and efficiently.

The equipment must be used according to the procedures in the manual and never for different purposes from the ones for which it has been designed.

1.1 Icons in the manual



Indicates a “NOTE”; we recommend particular attention in reading the subjects identified with this icon.



Indicates a “WARNING”; subjects identified with this icon concern safety aspects regarding the patient and/or the operator.

2. SAFETY ASPECTS

**WARNING:**

Read this chapter very carefully.

Villa Sistemi Medicali designs and makes their equipment according to safety requirements; moreover, they supply all necessary information for appropriate use and warnings relating to dangers connected with X-ray generators.

The manufacturer does not accept any responsibility for:

- Use of ENDOS AC/ACP equipment for purposes other than those for which it has been designed,
- damages to the equipment, the operator, the patient caused both by wrong installations and maintenance that do not follow the procedures contained in the user manuals and the installation provided with the equipment, and by wrong operating techniques,
- mechanical and / or electrical changes , made during and after installation, that differ from the ones in the Service Manual.

Only personnel authorised by the Manufacturer may carry out technical work on the equipment.

Only authorised personnel can remove the tubehead from its support and/or gain access to live parts.

2.1 Warnings

The equipment must be used according to the procedures in this manual and never for different purposes from the ones for which it has been designed.

Before carrying out any maintenance disconnect the equipment from the power line using the circuit breaker provided.

The utmost attention must be paid during the installation and calibration phase with the equipment connected to the line, since components directly supplied by the input line are accessible.

ENDOS AC/ACP is an electro-medical device and for this reason can be used only under the supervision of highly qualified medical staff in possession of all the necessary knowledge about X-ray protection.

The user is responsible for fulfilling all the legal requirements connected with the possession, installation and use of the equipment itself.

ENDOS AC/ACP is built for continuous running with intermittent load; for this reason the planned duty cycle must be observed.

Although the equipment is designed to provide a reasonable degree of protection from electromagnetic interference, according to IEC International regulations, it must be installed at an adequate distance from electricity transformer rooms, static continuity units, from two-way amateur radios and cellular phones. The latter can be used only at a minimum distance of 1.5m from any part of the equipment.

Any instrumentation or equipment for professional use located near ENDOS AC/ACP must conform to Electromagnetic Compatibility regulations. Non conforming equipment, with known poor immunity to electromagnetic fields, must be installed at a distance of at least 3m from ENDOS AC/ACP and supplied by a dedicated electric line.

ENDOS AC/ACP must be turned off when using electro-cautery or similar equipment in the vicinity of the equipment itself.

The equipment is not designed to be used in the presence of anaesthetic mixtures inflammable with air, oxygen or nitrous oxide.



WARNING:

For safety reasons, it is forbidden to overload the extension arm or the scissors arm in an anomalous way, for instance by leaning on it.

2.2 Protection from X-rays

Although dosage given by modern X-ray equipment is low on average, during the execution of the exposure, the operator must take all precautions to protect the patient and himself in compliance with the regulations in force.



WARNING:

Protection from X-ray radiation is regulated by law. The equipment must be used by specialised personnel only.

- a) The film (or the digital sensor) must be put into the patient's mouth manually or using the appropriate supports. If possible it must be held by the patient himself.
- b) During X-ray exposure, the operator must not come into contact with the tubehead or the collimator cone.
- c) During exposure, the operator must be at a certain distance from the X-ray source (at least 2 metres), in the opposite direction to X-ray beam.
- d) During exposure, the operator and the patient are the only people allowed in the room.
- e) The lead aprons should be used to reduce the undesirable effect of secondary radiation on the patient.

2.3 Environmental risks and disposal













Some parts of the equipment contain material and fluids which must be disposed of in special areas designated by the local health authorities at the end of the equipment's life cycle.

In particular the equipment contains the following materials and / or components:

- **Tubehead:** hard plastic materials, metal materials, glass, dielectric oil, lead, tungsten
- **Other parts of the equipment:** hard plastic materials, metal materials, printed circuits, iron-plastic materials.

2.4 Symbols in use

The following symbols are used in this manual and in ENDOS AC/ACP, besides the symbols on the keyboard (see chapter 6 of User's Manual):



Symbol	Description
	Equipment with applied parts Type B
	A number of machine parts contain materials and liquids that upon completion of the machine's life cycle must be disposed of at recovery centers established by the local health units
~	Alternate current
N	Connecting point to neutral conductor
L	Connecting point to live conductor
	Protection ground
	Functional ground
	OFF ; equipment not connected to electricity line
	ON ; equipment connected to electricity line
	Permission key to exposure; the permitted exposure status is displayed by switching on the corresponding green symbol
	Focal spot according to IEC 336
	X-ray emission
	Product identification code
	Serial number
	Warning: see the accompanying documentation
	Conformity to the EC 93/42 Directive and subsequent amendments and additions

3. DESCRIPTION

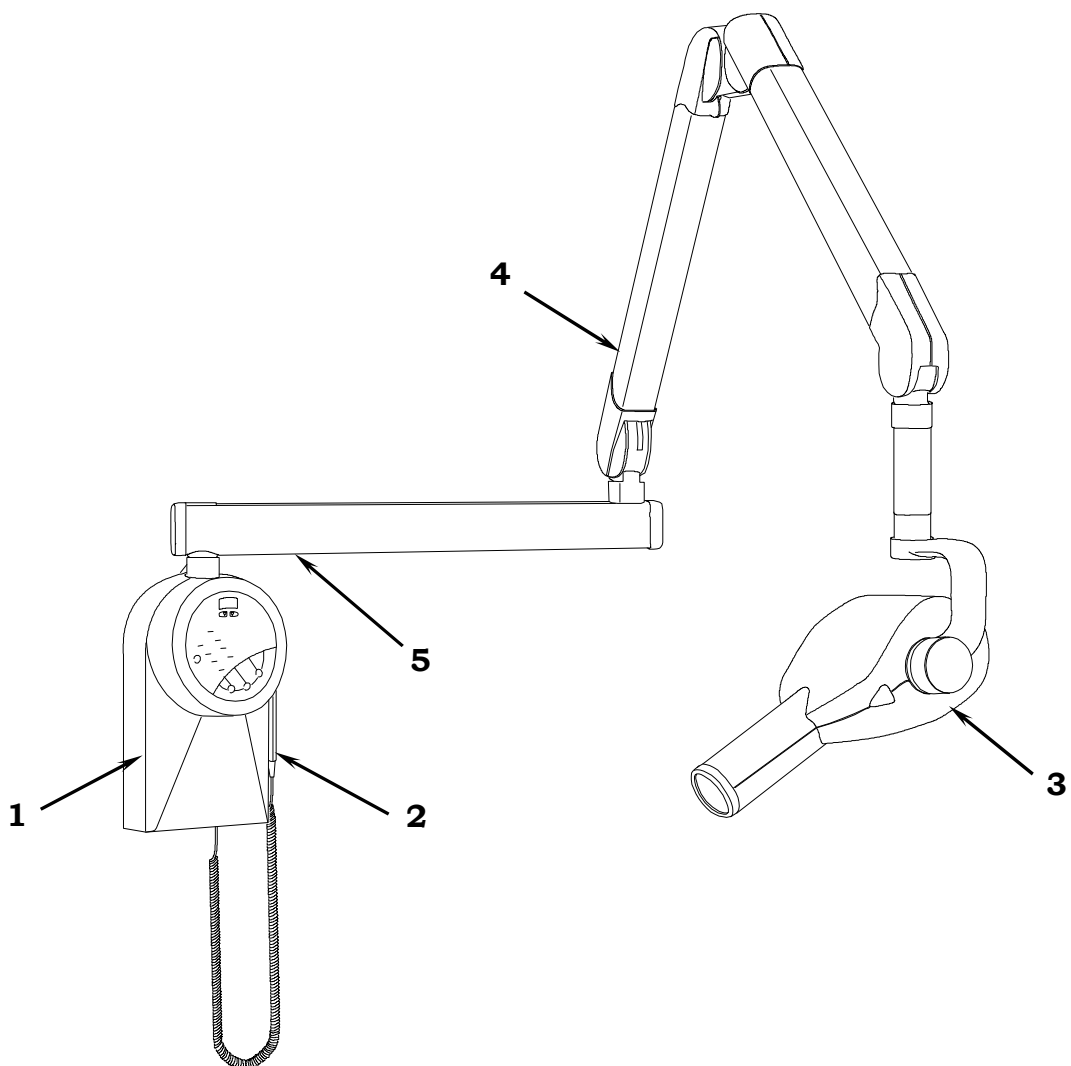
3.1 Identification labels



1a
ENDOS AC/ACP
label

	ENDOS xxx		
	X-MIND		
	Line: 120 V~	7.8 A (at 132 V~)	60 Hz
	Duty cycle: 1/32	Max exposure time: 3.2 s	
Manufactured: MMMYYYYY			
X-RAY CONTROL		Model: 8361306X02	
S/N: 23XXYYYY			
	This product complies with FDA radiation performance standards 21 cfr subchapter J, in effect at date of manufacture		
			

Manufactured by
VILLA SISTEMI
MEDICALI S.p.A.
20090 Buccinasco
MILANO - ITALY

CE 0051

1b
ETL certification
label

ETL LISTED
CONFORMS TO
us **UL STD 2601-1**
2001443
CERTIFIED TO
CAN/CSA STD C22.2 NO. 601.1

2
WARNING label

COMPLIES WITH DHHS PERFORMANCE STANDARD 21 CFR SUBCHAPTER J

WARNING:
THIS X RAY UNIT MAY BE DANGEROUS TO THE PATIENT AND OPERATOR UNLESS SAFE EXPOSURE FACTORS AND OPERATING INSTRUCTIONS ARE OBSERVED.
ELECTRICAL SHOCK AZARD - DO NOT REMOVE PANELS. RISK OF EXPLOSION DO NOT USE IN PRESENCE OF FLAMMABLE ANESTHETICS. FOR CONTINUED PORTECTION AGAINST RISK OF FIRE, REPLACE ONLY WITH SAME TYPE AND RATING OF FUSE.

DANGER:
CET APPAREIL DE RADIODIAGNOSTIC PEUT ETRE DANGEREUX POUR LE PATIENT ET L'OPERATEUR SI LES FACTEURS D'EXPOSITION ET LES INSTRUCTIONS NE SONT PAS SUIVIS. RISQUE D'EXPLOSION - NE PAS EMPLOYER EN PRESENCE D'ANESTHESIQUES INFLAMMABLES. POUR ASSURER UNE PROTECTION CONTINUE CONTRE LE RISQUE D'INCENDIE, UTILISER UNIQUEMENT UN FUSIBLE DE RECHARGE DE MEME TYPE ET DE MEMES CARACTERISTIQUES NOMINALES.

3a
Tubehead label
(X-ray tube type CEI)

Made in Italy	
TUBE HOUSING ASSEMBLY	Model: 8461406602
S/N: 31XXYYYY	Manufactured: MMM YYYY
Output: 70 kVp	8 mA at 120 V~
X-ray beam: $\varnothing \leq 6$ cm	at FFD 20 cm
■ 0.8 IEC 336	Total filtration: ≥ 2 mm Al
Preheating time: 100 ms	
X-RAY TUBE	Model: OCX 70/G
Manufacturer	CEI Bologna Italy
S/N:	
This product complies with FDA radiation performance standards 21 cfr subchapter J, in effect at date of manufacture	
	

Manufactured by
VILLA SISTEMI
MEDICALI S.p.A.
20090 Buccinasco
MILANO - ITALY

3b
Tubehead label
(X-ray tube type KAILONG)

Made in Italy	
TUBE HOUSING ASSEMBLY	Model: 8461406612
S/N: 31XXYYYY	Manufactured: MMM YYYY
Output: 70 kVp	8 mA at 120 V~
X-ray beam: $\varnothing \leq 6$ cm	at FFD 20 cm
■ 0.8 IEC 336	Total filtration: ≥ 2 mm Al
Preheating time: 100 ms	
X-RAY TUBE	Model: KL16-0.8-70G
Manufacturer	KAILONG China
S/N:	
This product complies with FDA radiation performance standards 21 cfr subchapter J, in effect at date of manufacture	
	

Manufactured by
VILLA SISTEMI
MEDICALI S.p.A.
20090 Buccinasco
MILANO - ITALY

4
DP arm label

REF	8161200602
SN	15YYXXXX

5
Extension arm label

REF	8161200X02
SN	10YYZZZZ

6
Collimator 30 cm (optional) label

BEAM LIMITING DEVICE	Model: 61614050
Diameter $\varnothing \leq 6$ cm	at FFD 30 cm
S/N:	40XXYYYY
Manufactured:	MMMM YYYY
This product complies with FDA radiation performance standards 21 cfr subchapter J, in effect at date of manufacture	
	

Manufactured by
VILLA SISTEMI
MEDICALI S.p.A.
20090 Buccinasco
MILANO - ITALY

3.2 Functions, Models and Versions

ENDOS AC/ACP intraoral radiographic equipment is composed of the following parts:

3.2.1 Extension arm and scissors arm

It is composed of a double articulated joint arm, enabling extension horizontally and vertically. The tubehead is balanced in all positions.

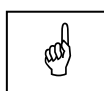

NOTE:

The scissors arm is designed to work correctly at a max. angle of 160°; so its use requires a flare angle of less than 160°.

Moreover, a horizontal extension arm can be added, available in various sizes, to meet all requirements.

3.2.2 Tubehead

The 70 kVp voltage, the 8 mA current and the use of a tube with grid reduce exposure times and the quantities of X-rays absorbed by the patient. The radiogenic equipment is provided with a collimator with 20 cm focus skin distance and a 6 cm X-ray emission diameter at the exit of the cone. The tubehead is connected to the arm by a guide, which allows 360° horizontal rotation and 290° vertical rotation.

Two alternate X-ray tubes can be used: both have the same characteristics and provide the same performance.

The tubehead, assembled with different X-ray tubes, are interchangeable so long as pre-heating time is set to the proper value indicated on the tubehead label (see chapter 8).

3.2.3 Timer

The name of ENDOS AC/ACP depends on the type of timer in use:

- **ENDOS ACP**

ENDOS ACP is a digital timer with microprocessor where exposure times can be selected both manually and automatically.

With automatic selection there is a choice of 30 pre-set times depending on the patient's size (small, medium or large) and the type of tooth and acquisition mode (film, digital).

There are 33 fixed manual selection times that vary from a minimum of 0.02 seconds to a maximum of 3.20 seconds.

The main feature of this timer is that it has an automatic exposure time compensation for drift of nominal voltage within $\pm 10\%$.

- **ENDOS AC**

ENDOS AC has the same features as the ENDOS ACP timer, excluding automatic and digital anatomic selection.

It has manual exposure time selection only.



NOTE:

A remote X-ray button configuration can be made, outside the exam room. This can be a pure door bell X-ray button or a device which also show status of the unit ("Ready" and "Exposure in progress").

3.3 Configurations

3.3.1 Standard configuration

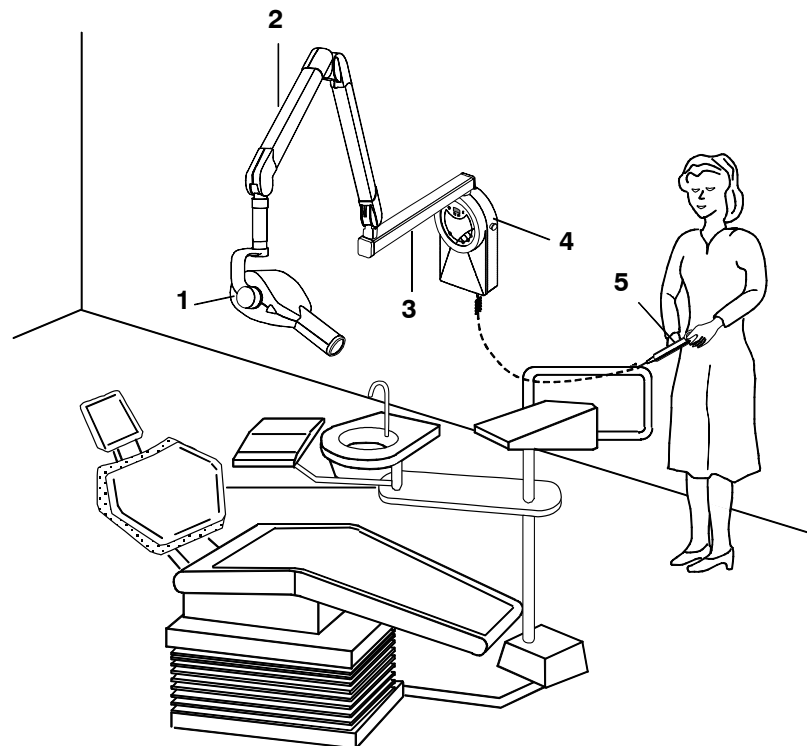
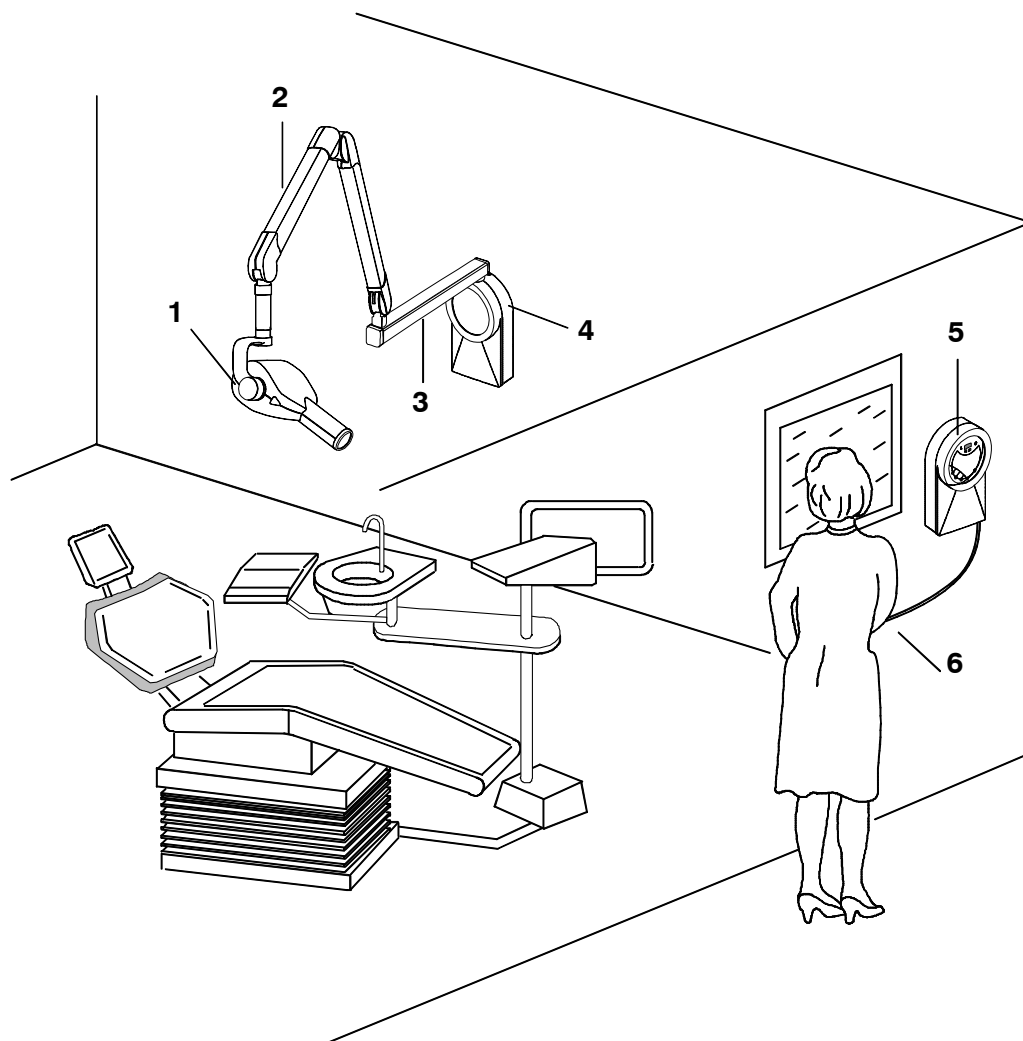

Figure 3-1

- 1** Tubehead
- 2** Scissors arm
- 3** Extension arm
- 4** Timer
- 5** X-ray button

3.3.2 Remote timer configuration*Figure 3-2*

- 1 Tubehead
- 2 Scissors arm
- 3 Extension arm
- 4 Wall support (kit code 8161301002)
- 5 Remote timer
- 6 X-ray button

3.3.3 Mobile stand configuration

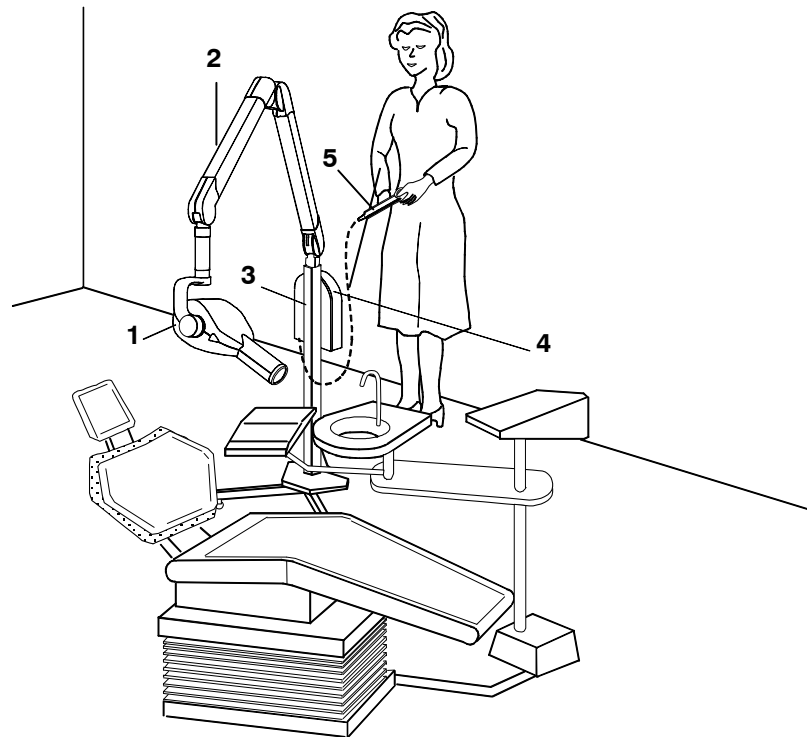

Figure 3-3

- 1** Tubehead
- 2** Scissors arm
- 3** Mobile stand
- 4** Timer
- 5** X-ray button

3.3.4 Remote X-ray button configuration

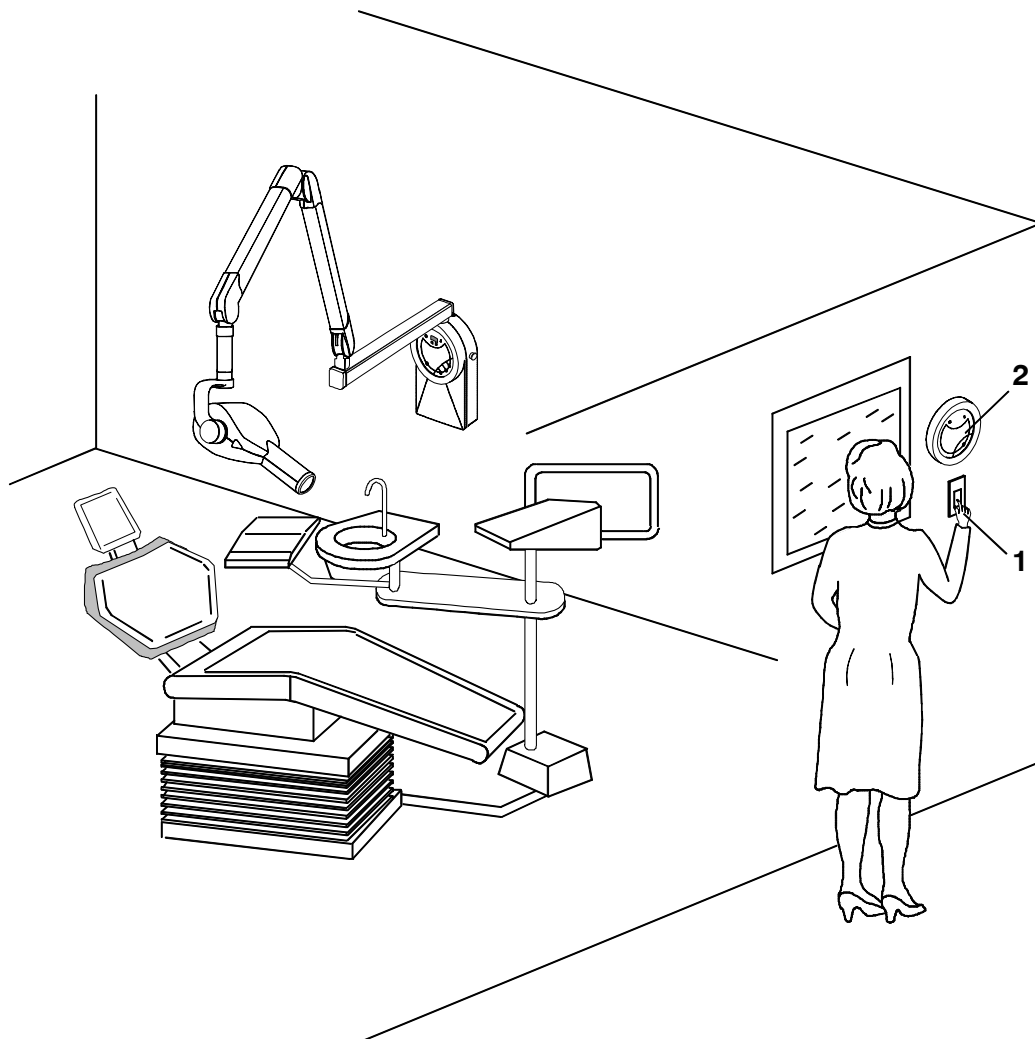

Figure 3-4

Alternative 1:

- 1 X-ray button (not supplied)

Alternative 2:

- 2 X-ray button + light signalling of "Ready" or "Exposure in progress" (supplied as kit P/N 6661309500)

4. TECHNICAL DATA

Technical features	
Equipment	ENDOS AC/ACP
Manufacturer	VILLA SISTEMI MEDICALI Via delle Azalee 3 20090 Buccinasco (MI) - ITALY
Class	Class I° with type B applied parts (EN 60601-1 classification) 
Protection level	Standard Apparatus IP20
Line voltage	120 V~ ± 10%
Line frequency	60 Hz
Max absorbed current	7.8 A rms impulsive @ 132 V ~
Power consumption	920 VA impulsive @ 120 V ~
Line voltage regulation	< 3 %
Main fuse	10 AF
Pre-set exposure times	from 0.02 to 3.2 s in 33 steps
Automatic selection (only for ENDOS ACP)	30 pre-set times
Exposure time accuracy of corrected time (*) (see paragraph 4.1)	± 10% or ± 32 ms (whichever is greater - see note paragraph 4.5)
Pre-selected exposure time accuracy (this is the value of timer setting pre-selected by the operator)	The absolute maximum deviation can be -100% +150% when line voltage changes within rated voltage range: it includes inaccuracy and correction due to line voltage changes (see paragraph 4.1)
Circuit type	Single phase self-rectifying with grid control
kV selection (high voltage value)	70 kVp
Tubehead current	8 mA
KV accuracy	± 15 %
Tubehead (anode) current accuracy	± 2 mA
Max. exposure time	3.2 s
Timer dimension	345×195×100 mm

(*) *This is the actual exposure time, pre-indicated on the timer during the enabled status and during exposure and determined by the internal algorithm as a function of line voltage.*

Tubehead features		
Manufacturer	VILLA SISTEMI MEDICALI Buccinasco (MI)	
Rated voltage	70 kV _p	
Tubehead power	430 W	
Pre-heating time	100 ms	
Total filtration	≥ 2 mm Al eq. @ 70 kV	
HVL (Half Value Layer)	> 1.5 mm Al eq.	
Transformer insulation	Oil bath	
Interval between exposures / duty cycle	32 times X-ray time / 1 : 32	
Focal spot	0.8 (IEC 336)	
Minimum focus to skin distance	20 cm (optional 30 cm cone)	
X-ray beam diameter (@ 20cm focus)	≤ 6 cm (optional 35x45 mm)	
Cooling	Convection	
Radiation leakage at 1 m	< 0.1 mGy/h	
Technical factors for radiation leakage	70 kV, 8 mA, 1 s duty cycle 1 exposure each 32 seconds	
X-ray tube features		
Manufacturer	CEI Bologna (Italy)	KAILONG Electronic (China)
Type	OXC/ 70-G with grid	KL16 - 0.8 - 70G
Inherent filtration	0.5 mm Al equivalent to 70 kV	0.4 mm Al equivalent to 70 kV
Anode tilt	19°	19°
Anode material	Tungsten	Tungsten
Rated voltage	70 kV	70 kV
Maximum filament current	2.8 A	2.8 A
Maximum filament voltage	4 V	4.1 V
Anode thermal capacity	6 kJ	7 kJ

Environmental conditions	
Operating temperature range	+10°C ÷ +40°C
Operating relative humidity range	30% ÷ 75%
Temperature range for transport and storage	-20°C ÷ +70°C
Max. relative humidity for transport and storage	<95 % non condensing
Min. atmospheric pressure for storage and transport	630hPa
Apparatus and detachable parts weight	
Gross weight including packing	30.4 kg
Net apparatus weight in standard configuration	25.4 kg
60 cm extension arm (standard)	2.9 kg
80 cm extension arm	3.5 kg
30 cm extension arm	1.9 kg
Scissors arm	9 kg
Timer plus wall plate	5 kg
Tubehead	8.5 kg

4.1 Method for correcting exposure times

This RX intraoral equipment features a special function called Computer Controlled Density which makes it possible to correct exposure time automatically when line voltage is different from its nominal voltage. A change in the line voltage affects the peak voltage applied to the RX tube and the high voltage value affects the Rx spectrum very significantly. This, in turn, affects the optical density of the image on the film. The task of the correction is to achieve the same optical image density irrespective of the variations in line voltage, within its permitted variation range of $\pm 10\%$. In short, this feature makes it possible to obtain the same quality of image without having to be concerned about possible line variations which occur frequently in many areas and which are almost impossible to prevent without resorting to costly equipment.

Automatic exposure time correction works with the following sequence: inside the timer there is a voltmeter which takes a constant reading of the line voltage, while the user selects the desired exposure time. After the user has chosen the exposure time he knows from experience to be the best for the type of X-ray he is going to take, the user himself presses the key enabling exposure and the timer shows on the screen the correct time that will be used for the exposure in progress, time that the timer itself has calculated according to the value of the line voltage measured an instant before pressing the key of the exposure permission.

**NOTE:**

ENDOS AC and ENDOS ACP timers work in step with the line frequency, so the calculated time is always rounded off to the multiple of the line frequency itself.

The correct exposure time shown once the timer has been enabled by the "Ready" key and during the execution of the X-ray is the time actually used by the equipment: it is calculated applying a correction factor to the time selected by the user, based on the empirical law relating to the optical density of the film with the high voltage peak value and consequently with the line voltage.

**NOTE:**

If the "Ready" key has been disabled in system configuration, the display will show the "corrected" exposure time only during exposure or holding the X-ray button pressed at the end of it.

The qualitative relation between the multiplication factor and the line voltage is shown in the following picture (for equipment configured to work at 120V):

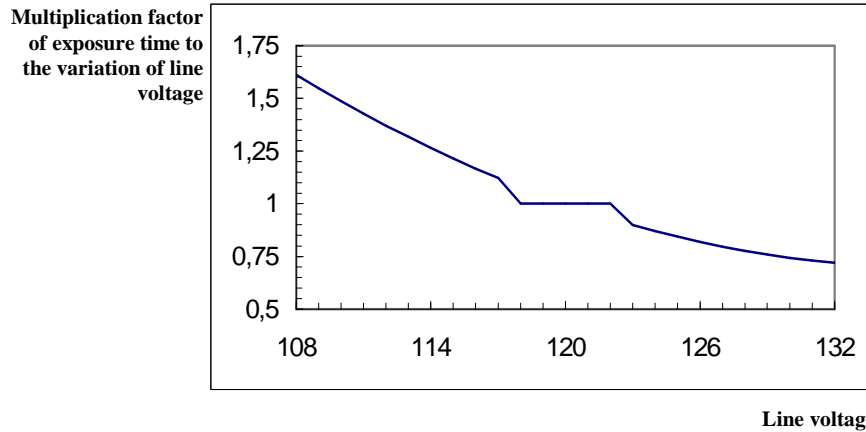

The following table allows to establish pre-indicated times and final real exposure times as a function of pre-selected time and line voltage variation.

line voltage	108V		112V		116V		124V		128V		132V	
	corrected exposure time (on the basis of current line voltage)	max/min exposure time due to intrinsic inaccuracy	corrected exposure time (on the basis of current line voltage)	max/min exposure time due to intrinsic inaccuracy	corrected exposure time (on the basis of current line voltage)	max/min exposure time due to intrinsic inaccuracy	corrected exposure time (on the basis of current line voltage)	max/min exposure time due to intrinsic inaccuracy	corrected exposure time (on the basis of current line voltage)	max/min exposure time due to intrinsic inaccuracy	corrected exposure time (on the basis of current line voltage)	max/min exposure time due to intrinsic inaccuracy
line voltage correction factor:	1,61		1,37		1,17		0,87		0,78		0,72	
preselected time (ms)												
20	32	64	27	59	23	55	17	49	16	48	14	46
		0		0		0		0		0		0
40	64	96	55	87	47	79	35	67	31	63	29	61
		32		23		15		3		0		0
60	97	129	82	114	70	102	52	84	47	79	43	75
		65		50		38		20		15		11
100	161	193	137	169	117	149	87	119	78	110	72	104
		129		105		85		55		46		40
200	322	354	274	306	234	266	174	206	156	188	144	176
		290		242		202		142		124		112
400	644	676	548	580	468	500	348	380	312	344	288	320
		612		516		436		316		280		256
800	1288	1320	1096	1128	936	968	696	728	624	656	576	608
		1256		1064		904		664		592		544
1000	1610	1642	1370	1402	1170	1202	870	902	780	812	720	752
		1578		1338		1138		838		748		688
1200	1932	1964	1644	1676	1404	1436	1044	1076	936	968	864	896
		1900		1612		1372		1012		904		832
1500	2415	2447	2055	2087	1755	1787	1305	1337	1170	1202	1080	1112
		2383		2023		1723		1273		1138		1048
2000	3220	3252	2740	2772	2340	2372	1740	1772	1560	1592	1440	1472
		3188		2708		2308		1708		1528		1408
2500	4025	no exposure	3425	3457	2925	2957	2175	2207	1950	1982	1800	1832
		no exposure		3393		2893		2143		1918		1768
3000	4830	no exposure	4110	no exposure	3510	3542	2610	2642	2340	2372	2160	2192
		no exposure		no exposure		3478		2578		2308		2128

no exposure = the timer does not allow exposure times longer than 4 sec

4.2 Method for measuring technical factors

- kV_p** KV_p value is defined as the stationary value of high voltage applied to the tube which settles on load after preheating time.
KV_p value is measured by a non-invasive instrument, with accuracy of over 2%, to the nominal value of line voltage.
A direct high voltage measurement can be made only by disassembling the tubehead. **This operation can be executed only in the factory.**
- mA** The anodic current value is defined as the average value of stationary current which settles on load after pre-switching time.
The anodic current value is measured using a digital voltmeter measuring the voltage drop at the ends of the resistance from 1 kΩ, 1% assembled on the tubehead. To take this measurement, remove the side plastic plug of the tube support; connect the ground voltmeter terminal on the yellow/green cable clamp screw and insert the positive terminal into the contact at the end of the grey cable. The digital voltmeter must be selected on DC, and the relation of transformation is given by 1 mA = 1V. Execute an exposure of at least 1 sec.
- t** The exposure time value is the time during which the value of the anodic peak current exceeds 25% of the steady state value. The time taken to reach this condition is called "pre-heating time".
The measurement must be taken at nominal line voltage, measuring the anodic current wave-form on the 1kΩ resistance and using a memory oscilloscope.
Exposure time measurements using non-invasive equipment can lead to systematic errors in exposure time measurements which cannot be quantified and which depend on the equipment used for measuring (see paragraph 4.3).

4.3 Correct use of dosimeters to measure exposure times

The spread of non-invasive equipment to measure the functional parameters of RX equipment has introduced a series of interpretation problems when measuring exposure times.

The source of the problem is in the characteristic rise curve of the RX tube's anodic current which is represented in the picture:

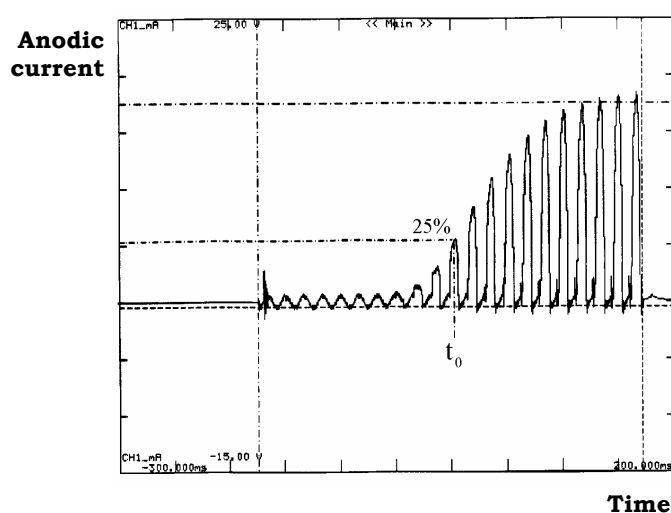

According to IEC60601-2-7 (1998) regulations, "in equipment where the filament is switched on and high voltage is applied simultaneously, the exposure time is calculated as the interval between the instant when the anodic current exceeds 25% of the nominal value and the instant when it goes below such value".

This method is defined as invasive because it requires that the anodic current flowing through a resistance inside the tubehead must be measured.

Non-invasive methods are definitely easier and faster compared with the invasive method, but they are prone to errors which can be considerable when determining exposure time. In fact some of these devices start counting exposure time as soon as a small quantity of radiation reaches the measuring chamber with the result that they take longer times than the ones determined by the invasive method applied by the manufacturer.

Consequently, calculations obtained by these non-invasive methods can erroneously lead to the conclusion that the equipment timer is not accurate. Actually the difference is connected to the method adopted in measuring the exposure time.

By using a tube with grid it is possible to reduce to the minimum the time required for the anodic current, and as a consequence, the dose adjustment to reach the steady state, so there is very little difference between the exposure time measurement using the invasive and the non invasive method.

Corrective actions

A practical method can be applied to get round the problem which can be described this way:

- In a graph you report the values of times measured using the equipment compared with the ones displayed by the timer (automatically corrected for the line variations): the dots of the graph are interpolated with a straight line (if possible by the least square method or more simply in a graphic way).
- You determine the intercept on the Y axis of this straight line: this can be assumed as the time value that the non-invasive device adds to each measurement due to the radiation which reaches the device before the anodic current is 25% of its maximum value.
- Then you subtract this "offset" time from all the device measurements and you proceed with comparing the time measurements displayed by the timer.

4.4 Curves tube features

OCX / 70-G

Feature of emission

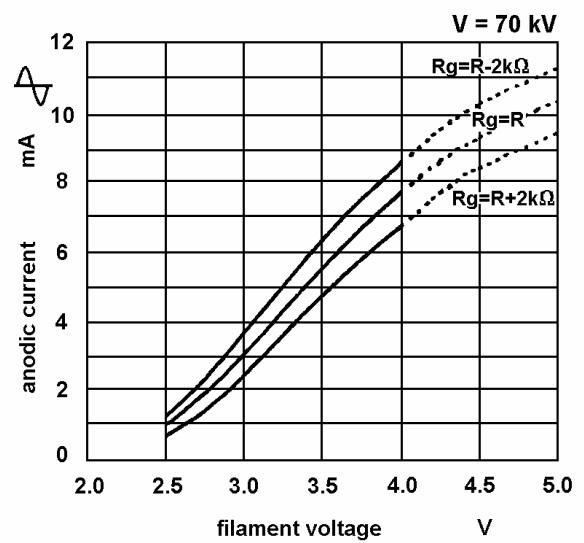
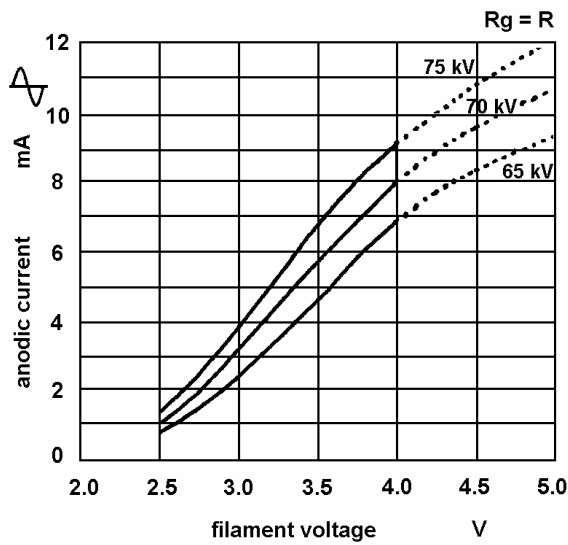

Load

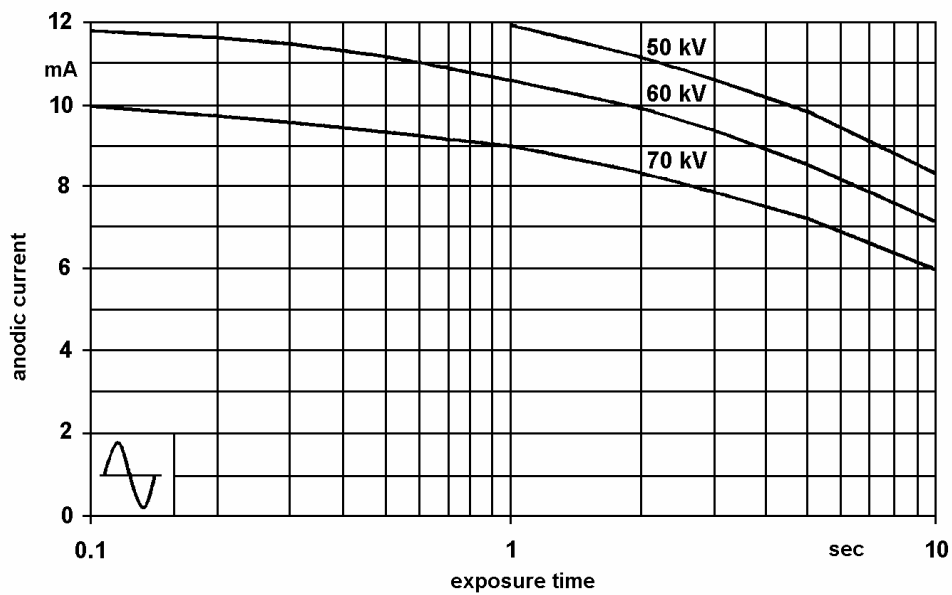

Curve anode cooling

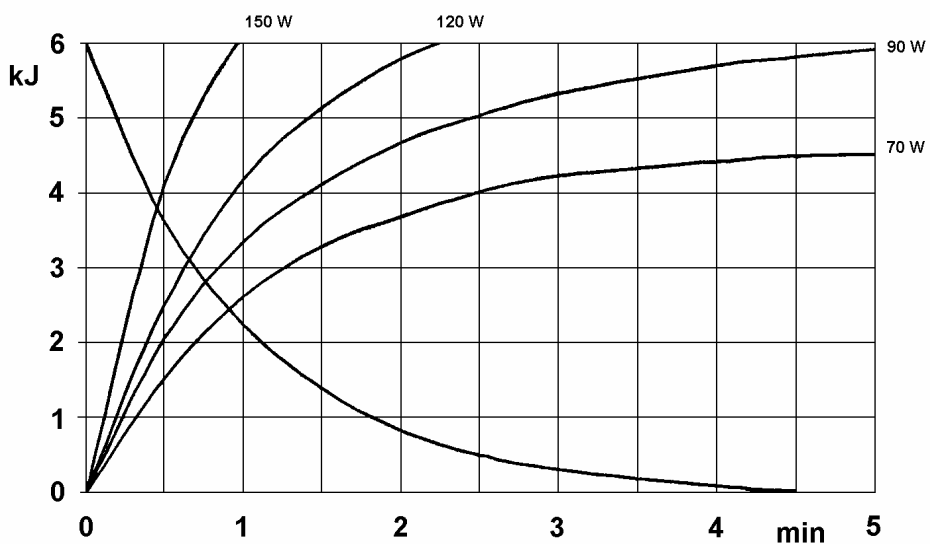

Curve tubehead cooling

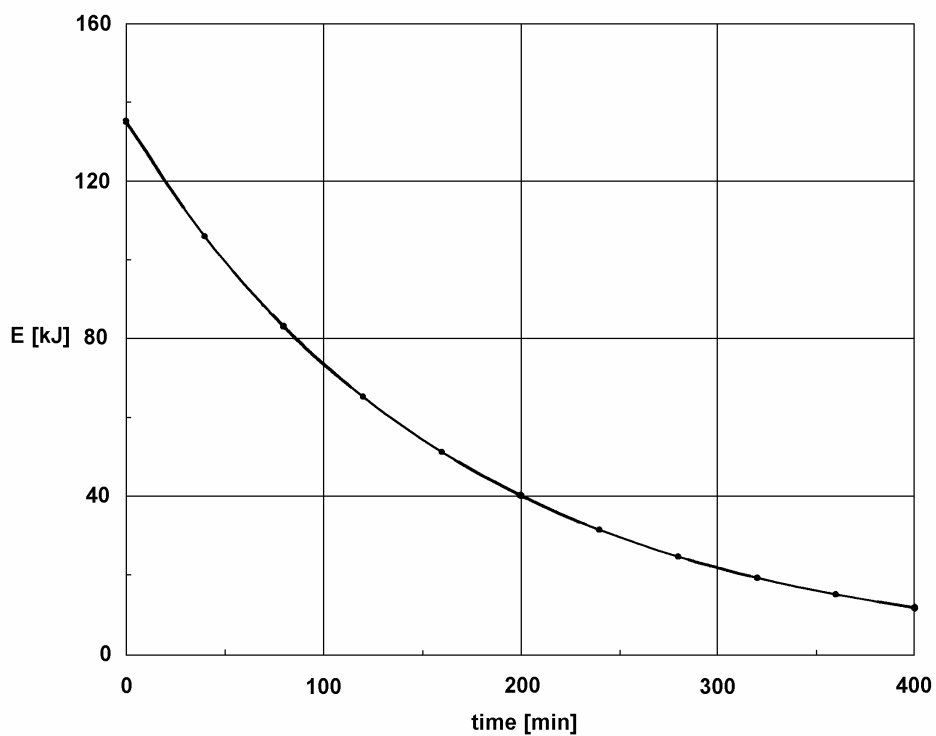

KL16 – 0.8 – 70G

Feature of emission

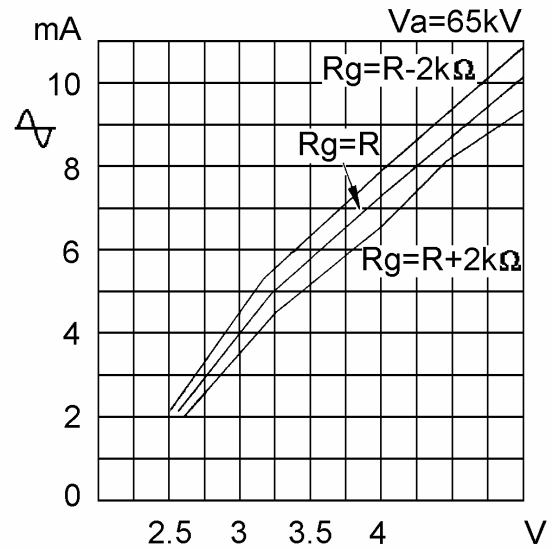
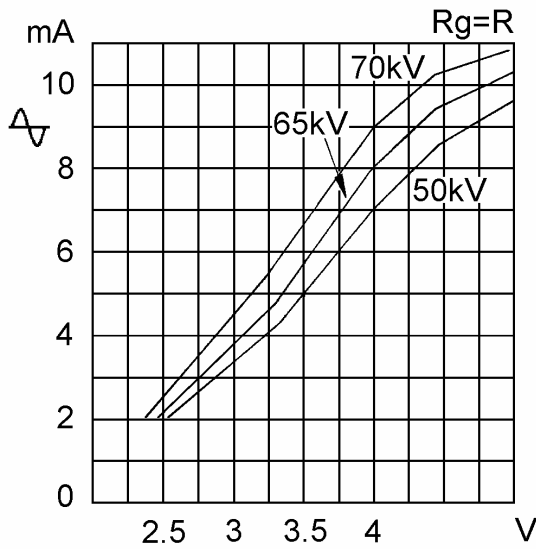

Filament characteristics

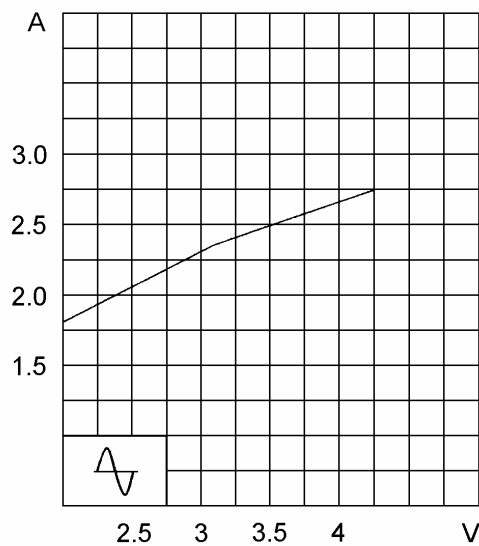

Heat storage (kJ)

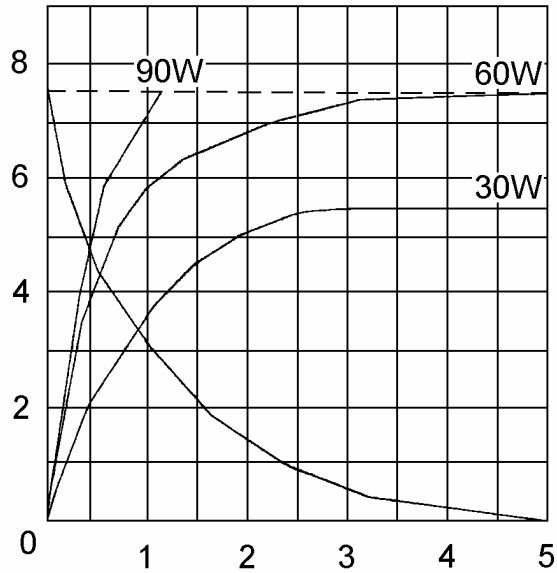

Curve tubehead cooling

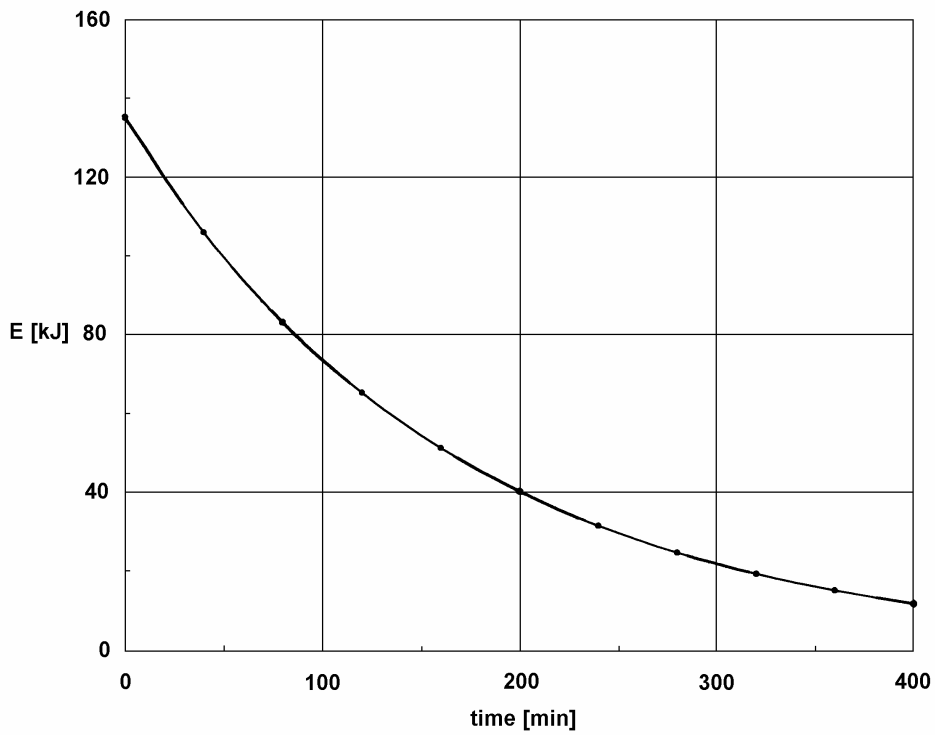

4.5 Reference standard

Enforceable regulations:

21 CFR

CEE 93/42: EN 60601-1
EN 60601-1-2
EN 60601-1-3
EN 60601-2-7 (see NOTE)
EN 60601-2-28



NOTE:

The technology employed in AC intraoral equipment, where the line voltage is applied simultaneously to the high voltage transformer and to the filament of the Rx tube, causes the two following deviations according to EN 60601-2-7 (ed.1998) requirements:

- a)** The exposure time cannot be defined with an accuracy lower than the length of a 50Hz line period (20ms) and than two 60Hz line periods (16.6ms).

In fact exposure time is defined as the interval between the instant when the anodic current exceeds 25% of the steady state value and the instant when it goes below this value. It is evident that in the anodic current rise current (see Figure paragraph 4.3) you have the uncertainty of 1 peak in determining the first peak which exceeds 25% of the steady state anodic current.

When running at 60Hz you must also consider that selectable times in the timer are not always multiples of the line period. This introduces a further approximation that the timer executes automatically to carry the selected time to the nearest multiple of the line period.

- b)** EN 60601-2-7 (ed. 1998) regulation defines precisely that for each pair of exposure times (in ENDOS AC/ACP equipment is the only selectable parameter), with a near relation, but lower than 2, dose linearity is calculated by the formula:

$$\left| \frac{Dose(t1)}{t1} - \frac{Dose(t2)}{t2} \right| \leq 0.2 \times \frac{\left(\frac{Dose(t1)}{t1} + \frac{Dose(t2)}{t2} \right)}{2}$$

Again, due to the characteristic the anodic current rise curve in AC equipment, the linearity limit is not respected for very short exposure times.

In fact it is evident that for any exposure time a "basal dose" is emitted, produced in the period between the application of voltage to the tubehead and the time when anodic current exceeds 25% of steady state, assumed as the exposure time start.

Moreover, the interval between exceeding 25% of the steady state anodic current and reaching running point, the anodic current grows and with it the dose rate, making the emitted dose non-proportional to the exposure time.

The use of a tube with grid substantially limits the "basal" dose and also the dose emitted at the start of the exposure time, before the anodic current reaches the stationary status.

In ENDOS AC/ACP equipment, typically the basal dose and the dose emitted in the interval when the anodic current varies between 25% of the running value and stationary point is very low, thanks to the tube with grid and this makes it possible to guarantee that the linearity requirements contained in EN 60601-2-7 (ed.1998) are respected for exposure times starting from 60ms.

4.6 Overall dimensions

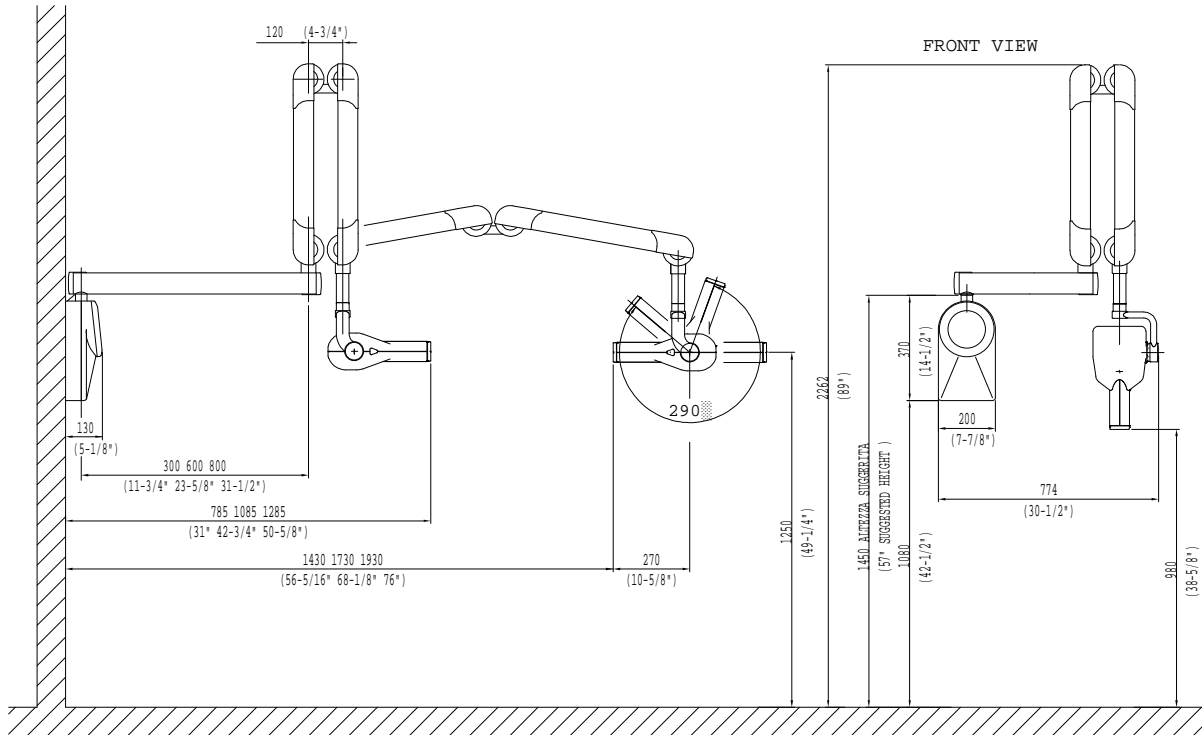

Figure 4-1: Overall dimensions wall version

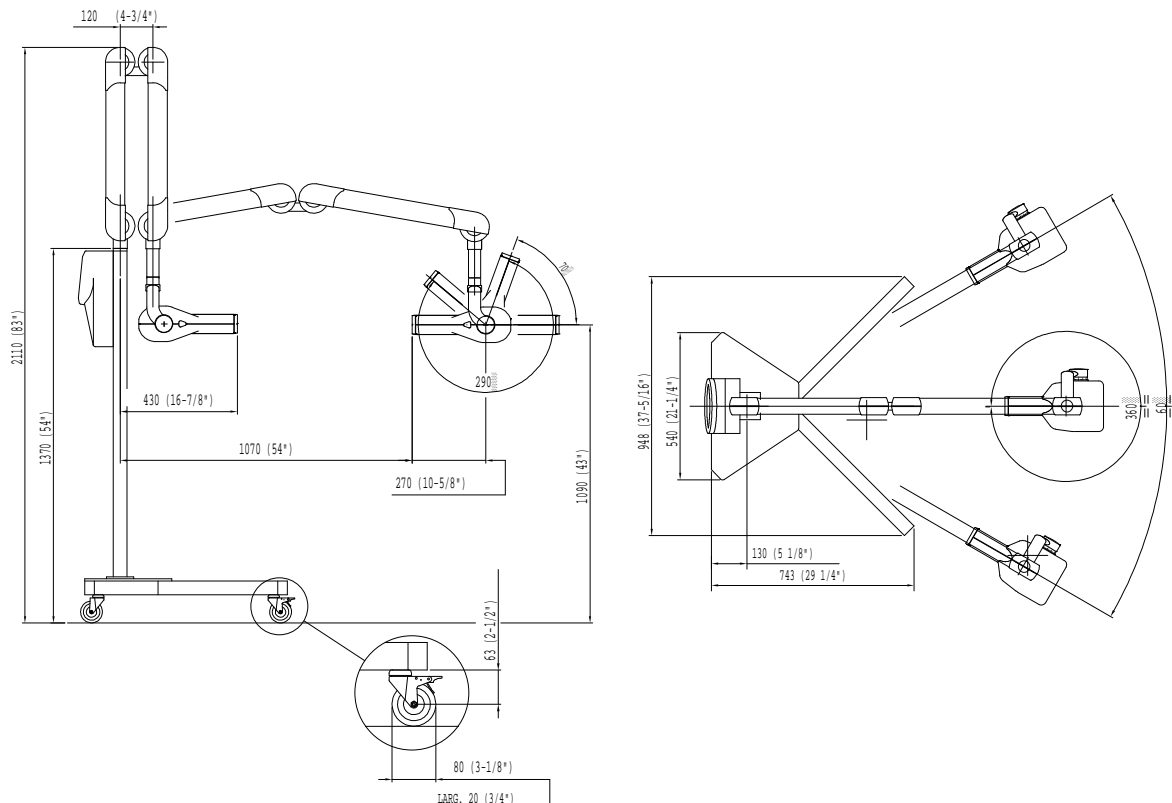

Figure 4-2: Overall dimensions Mobile Stand version

5. PRE-INSTALLATION

ENDOS AC/ACP does not require any particular operations during the pre-set up phase; just follow the instructions given in paragraph 5.1 . When ENDOS AC/ACP connections must be made into the wall it is better to make these before installing the intraoral X-ray equipment, considering the overall dimensions and the requested height from the floor as reported in paragraph 4.6.

The supplier can give the necessary assistance and technical advice concerning pre-set up; construction work and the pre-set up phase are at the customer's expenses.

5.1 Mounting methods

**NOTE:**

This chapter is valid for Wall version. The user does not need to assess the consistency of the wall for Stand version.

The installer is responsible for assessing the consistency of the wall. The extraction load on each screw is 58kg for the wall version standard assembly (3 mounting screws) and 110kg for the wall version "single stud" assembly (2 screws in line).

For each type of wall use the appropriate mounting method complying with the following specifications which guarantee a safety factor 4:

- Wooden uprights: self-threading screws 8x70 A 4.8 (provided with the installation kit)
- Full or concrete bricks: screw anchors (provided with the installation kit) in cast iron M8 or chemical screws WURTH (not provided)
- Hollow bricks: chemical screws (not provided).

A counter-plate must be used with walls with a lower resistance (see paragraph 6.4.1).

**WARNING:**

The Manufacturer is not responsible for any installations that do not comply with the specifications stated above.

5.2 Electric pre-setting

The supply source must be able to supply the following characteristic values:

- Single-phase supply + ground 120V \pm 10%
- Frequency 60 Hz
- Absorbed current 7.8 Arms at 132V
- Line voltage regulation 3% max at 132V.

A circuit breaker with overcurrent protection must be connected to the intraoral X-ray equipment with the following features:

- Rated current 10 A
- Residual current sensitivity 30 mA.

The apparatus must be connected to a line supplied with an adequate ground in compliance with IEC regulations.

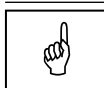

NOTE:
The device is supplied as unit to be installed permanently (EN60601-1 – paragraph 19). Please DO NOT connect the unit to the line using a normal socket, to avoid compromising the electrical safety.



NOTE:
The maximum distances between the electric board and the entry supply terminal board must be less than 20mt and the connecting cable must be 1.5mm² (16 AWG).



NOTE:
The mobile stand is supplied without the mains plug to permit the free connection at every socket.
Is in charge to the installer supply a mains plug compatible with the local electrical network with follow features: connection 2P+Earth protection, minimum working voltage 120Vac, minimum rated current 10A.
Then install the mains plug on the cable by connecting the Y/G wire in the earth protection connector and the others conductors in the others free connectors.
The mains plug must be in compliance with the laws and directive in force of the Country of use and report at least one quality/safety mark released by a recognized Notified Body.

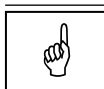

NOTE:
In Remote Timer version where you need to put a connecting extension (not supplied), **the maximum distances between timer and arm must be less than 12mt and the connecting cable must be 2.5mm² (14 AWG).**

6. INSTALLATION

6.1 Wall installation

ENDOS AC/ACP intraoral X-ray equipment is shipped pre-assembled in sub-assys.

Mechanical assembly work consists solely in assembling these units. All the mechanical components are therefore adjusted before delivery; not only is there no need to carry out any adjustment on these parts but it would also cause the equipment to malfunction; any adjustment must be carried out by authorised personnel only.

6.1.1 Timer set up (standard configuration)

1. To be sure that the equipment is in the correct position we recommend you put the provided template (3) (code 39619100) in the requested position, in this way identifying the requested wall-mounting position. Considering the overall dimensions of the equipment, put the top part of the template at 1450 mm from the floor.



WARNING:

The plate must be placed so that the entry hole of the supply cables corresponds with the point from which these cables exit the wall. The installer will assess the consistency of the wall taking into consideration the screw extraction load specified in paragraph 5.1.

2. Mark the mounting points and make the respective holes with a diameter corresponding to the chosen screws.
3. Remove the plastic timer cover (1) loosening the two sealing screws (2) placed on the lower part and lifting the cover from the bottom to the top to let the upper clamps out. Be careful of the board connection cables.
4. Fix the timer to the wall using the relevant screws (4).

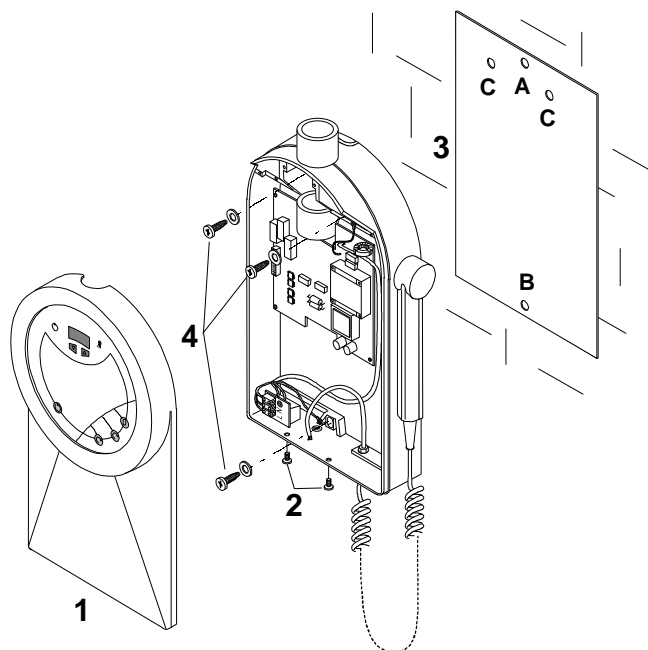
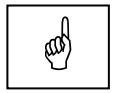

Figure 6-1

Later start assembling the extension arm following the instructions as follows.

1. Insert the extension arm into the arm support block which is an integral part of the wall support plate.



NOTE:

You must keep the arm orthogonal to the plate to be able to insert the shaft into the bush placed inside the support.

2. Check that the arm is level using a bubble level; if it is not level it is better to release the mounting screws on the wall plate and make the necessary adjustments.
3. The horizontal check must be performed in the three orthogonal positions (arm parallel to the wall on the right, on the left and perpendicular to the wall itself).
4. At the end of the above operations, assemble the extension arm frictioning mechanism block (1); this frictioning mechanism is included in the mounting hardware packaging (code 61613018).
5. Assemble the arm rotation stop screw (2 – M5x6) in the hole provided on the shaft; this screw is supplied with the frictioning mechanism.



NOTE:

The purpose of the frictioning mechanism and the rotation stop pin is to prevent the extension arm from becoming detached.

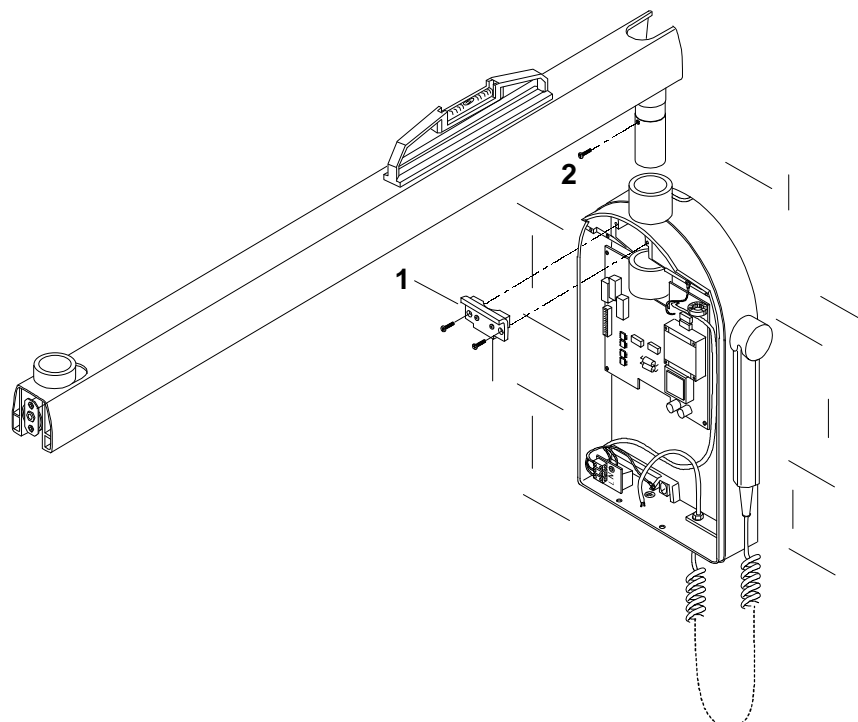

Figure 6-2

6.1.2 Wall support set-up (Remote Timer configuration)

1. To be sure that the equipment is in the correct position we recommend you put the provided template (3) (code 39619100) in the requested position, in this way identifying the requested wall-mounting position. Considering the overall dimensions of the equipment, put the top part of the template at 1450 mm from the floor.



WARNING:

The plate must be placed so that the entry hole of the supply cables corresponds with the point from which these cables exit the wall. The installer will assess the consistency of the wall taking into consideration the screw extraction load specified in paragraph 5.1.

2. Mark the mounting points and make the respective holes with a diameter corresponding to the chosen screws.
3. Remove the plastic timer cover (1) loosening the two sealing screws (2) placed on the lower part and lifting the cover from the bottom to the top to let the upper clamps out.
4. Fix the timer to the wall using the relevant screws (4).

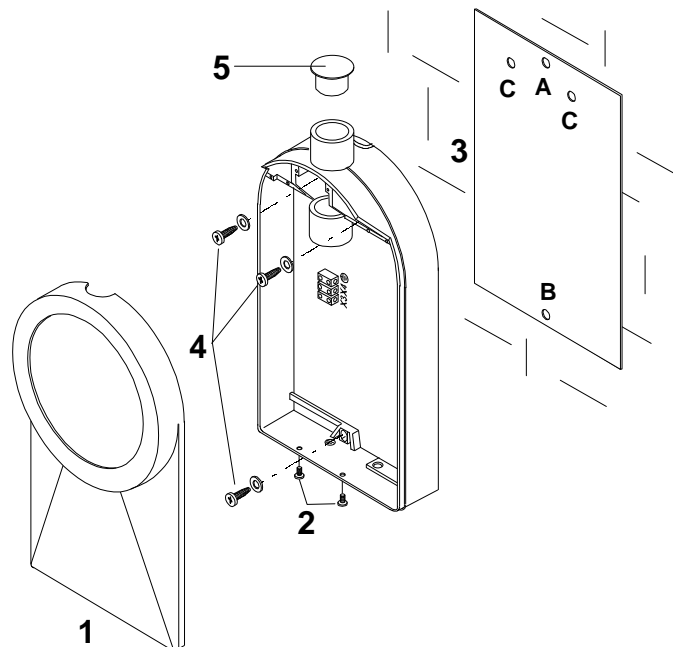

Figure 6-3

5. Remove the plug (5) positioned in the hole for the extension arm and put it on the Remote Timer box.

Later start assembling the extension arm following the instructions at paragraph 6.1.1.

6.1.3 Timer set up (Remote Timer configuration)

- 1 To be sure that the equipment is in the correct position we recommend you put the provided template **(3)** (code 39619100) in the requested position, in this way identifying the requested wall-mounting position. Considering the overall dimensions of the equipment, put the top part of the template at 1450 mm from the floor.
- 2 Mark the mounting points and make the relevant holes with the diameter corresponding to the chosen screws.
- 3 Remove the plastic timer cover **(1)** by loosening the two sealing screws **(2)** placed on the bottom part and lifting the cover from the bottom to the top to let the upper clamps out. Be careful of the cables connecting the boards.
- 4 Fix the timer to the wall using the provided screws **(4)**.

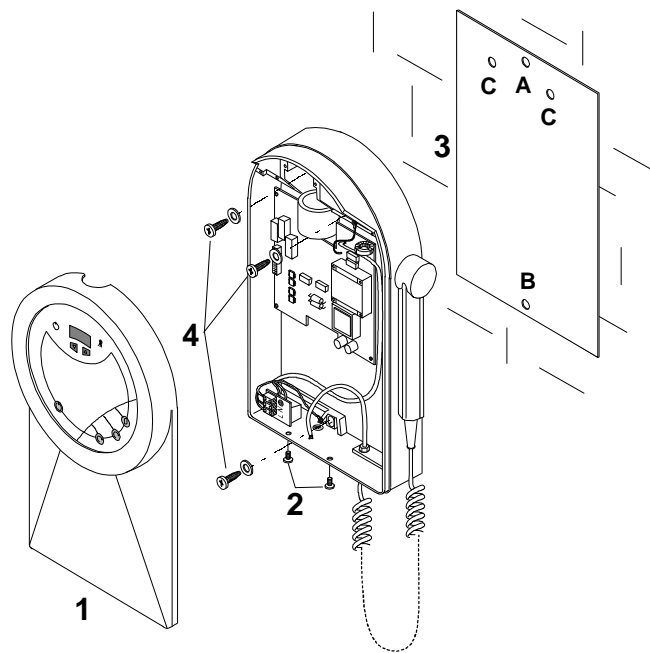

Figure 6-4

6.1.4 Assembling the mobile stand and timer installation

1. Cross the two base tubes (1) into the provided cut, fixing them together with the screw (2) and relevant nut (3). Do not tighten the screw completely.
2. Position the base plate (4) and fix it with the four screws (5). If necessary, reposition the two base tubes(1) slightly in order to align the relevant holes on the plate.
3. Lock the nut (3) in order to block the base tubes (1) permanently.
4. Assemble the stand column (6) on the base plate (4) with the four screws (7).
5. Assemble the timer support plate (8) to the stand column, fixing it with the two screws (9).



WARNING:

The timer must be fixed to the support plate after assembling the scissors arm (see paragraph 6.2.2).

6. Remove the plastic timer cover (10) by loosening the two sealing screws (11) placed on the lower part and lifting the cover from the bottom to the top to let the upper clamps out. Be careful of the cables connecting boards.
7. Fix the timer (12) onto the support plate (8) with the two screws (13) taking care to thread the supply cable and the cable coming from the scissors arm inside the hollow one (14). Check that the upper level is level using a bubble level.

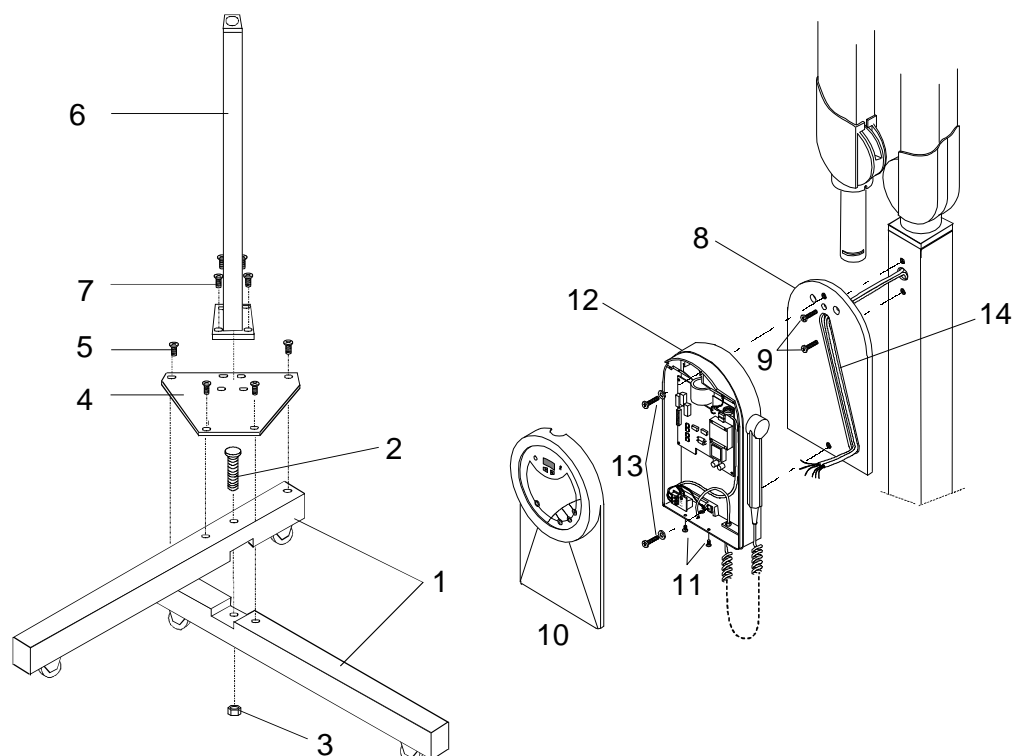

Figure 6-5

6.1.5 X-ray button

The X-ray button and the relevant support are in the box with an installation kit that gives two options:

- mounting on the timer side; remove the small plug placed on the right hand wall of the timer box and screw the relevant support
- mounting on the wall; use the screw provided with the support to fix the support itself to the wall in the requested position.

6.2 Assembling the scissors arm

6.2.1 Assembling the scissors arm (DP arm)

1. Remove the friction group fixing plate fixed to the extension arm with three screws (scissor arm side). Take note that the upper screw is shorter than the other two and has to be mounted in the same position.

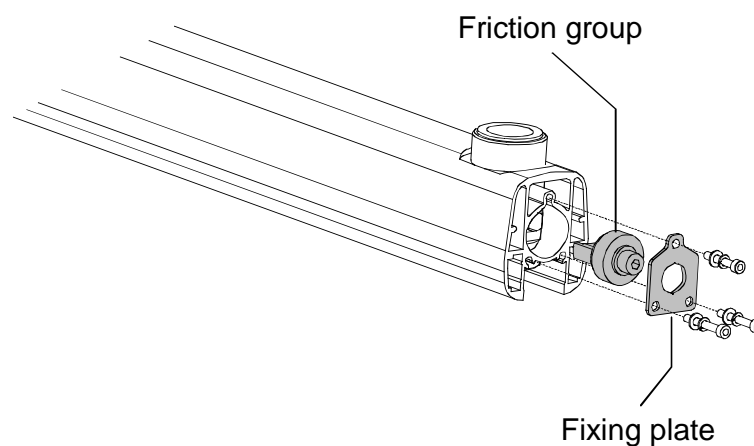

Figure 6-6

2. Remove also the friction taking care not to lose the spring washer. Here following is indicated the right sequence of the washers.

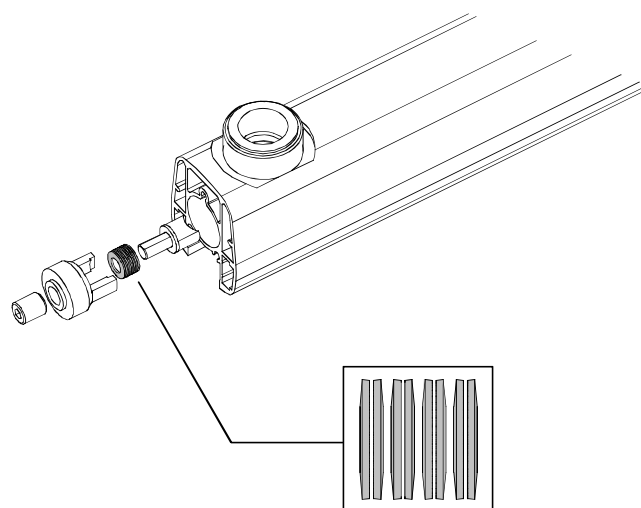

Figure 6-7

3. Remove the fixing bushing. This operation will permit an easier insertion of the scissor arm group into the extension arm.

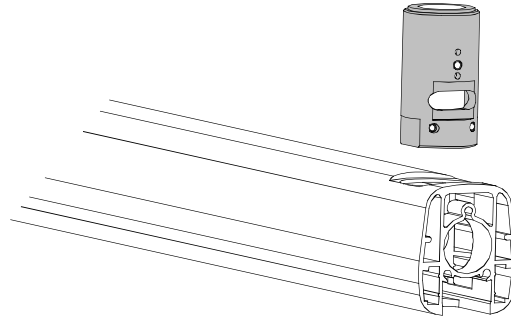

Figure 6-8

4. Insert the extension arm pin in the bushing; during insertion take care to the O-Rings present in the bushing. The friction group fixing holes must be toward tube head support.

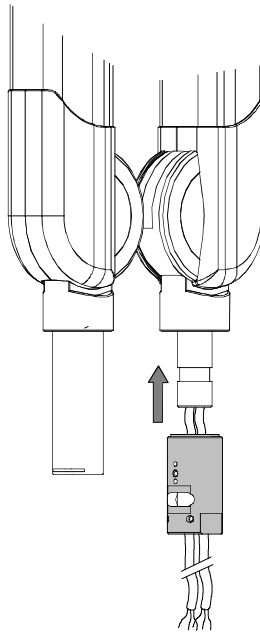

Figure 6-9

5. Insert the scissor arm into the extension arm, aligning the bushing fixing holes to the extension arm screws. The cable and the braiding coming from the DP arm must be pulled out from the extension arm.

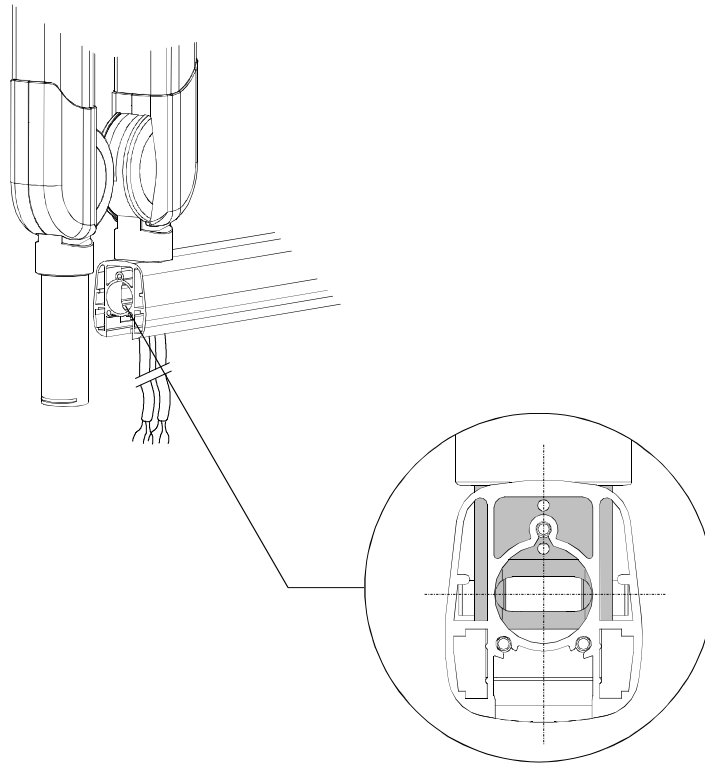

Figure 6-10

6. Mount the friction group and fix the plate using the shorter screw in the top hole (Figure 6-6). Tighten the grub screw until it is frictioned but don't force the friction. It has to be adjusted only if necessary.
7. Insert the cable coming from DP arm inside the extension, following the diagram in Figure 6-11.

8. Run the cable inside the extension arm until they come completely out at the opposite end; insert the cable itself inside the rotation pin as shown in the following figure.

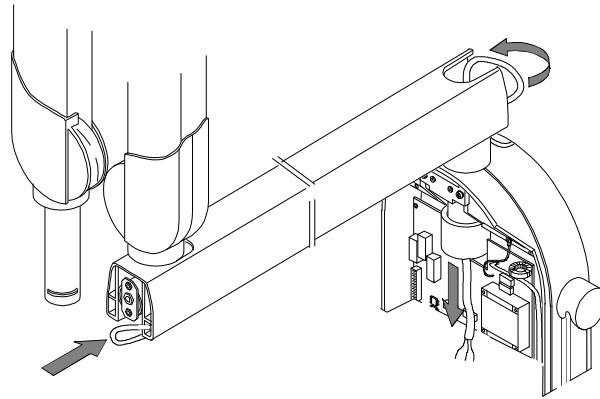

Figure 6-11

9. Check that the DP arm is perfectly inserted; check that the rotation of the scissors arm inside the extension arm is the one ergonomically requested by the operator, otherwise work on the frictioning mechanism (**1** - Figure 7-2) until you get the requested run.



NOTE:

This frictioning mechanism is also used to prevent the scissors arm from becoming detached and for this reason it must never be loosened completely.

10. Assemble the tubehead (see paragraph 6.3).
11. Remove the scissors arm safety clamp and check the ergonomics of its movement again, otherwise adjust the frictioning mechanism again (**1**) and/or the tension of the arm balance springs (see paragraph 7.2.3).
12. Assemble the front covers of the extension arm included in the mounting hardware packaging.

6.2.2 Assembling the stand arms set

Assemble the scissors arm (there is no extension arm in this configuration), being careful to insert the spacer (1) (p/n61613056) into the rotation pin.



NOTE:

Be sure that the two pins are inserted into the spacer as showed in the drawing.

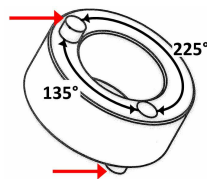

NOTE:

Keep the arm perfectly orthogonal to the pole when inserting the extension arm rotation pin.

Do not release the arms of the scissors arm from their sealing packing.

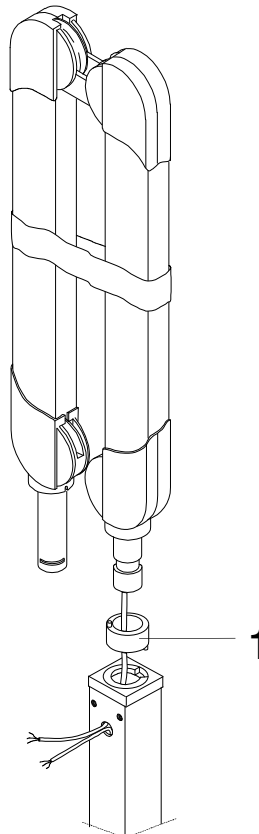

Figure 6-12

6.3 Tubehead assembly

1. Insert the protection cover (1) into the D.P. arm until you can see the insertion slot of the safety elastic ring (2). Hold it up and insert the ring itself partially.
2. Insert the rotation pin of the tubehead onto the sliding contact for about half of its length and put the elastic ring (2) into the two transversal cuts.

**NOTE:**

The elastic ring must be inserted on the same side as the safety screw to prevent the cover from moving excessively.

3. Insert the rotation pin completely into the sliding contact, fixing it with the safety ring (2). Insert the grounding clip (3), making sure that the pins enter the holes and fix it by the supplied screw (4). Lower the protection cover (1); only now is it possible to release the scissors arms.
4. Put the safety screw (5) which clamps the protection cover.

**NOTE:**

The function of the cover is to prevent the safety ring from going out of position.

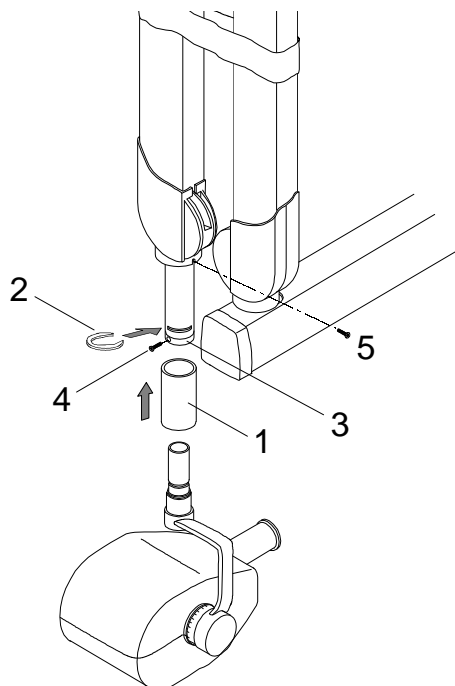

Figure 6-13

6.4 Installation of the optional parts

6.4.1 Counterplate

A counterplate must be used on the opposite side of the wall when installing on walls that are too weak.

1. Put the template (3) (code 39619100) in the requested position to identify the requested mounting position on the wall. Considering the overall dimensions of the equipment put the top part of the template at 1450 mm from the floor.
2. Mark the mounting points and make holes right through the wall at the marked points.
3. Remove the plastic timer cover (1) by loosening the two sealing screws (2) on the bottom part and lifting the cover from the bottom to the top to let the top clamps out. Be careful with the boards connecting cables.
4. Put some threading pins (5) (not provided) through the wall and fix the counterplate (4) onto the back of the wall after positioning the timer.

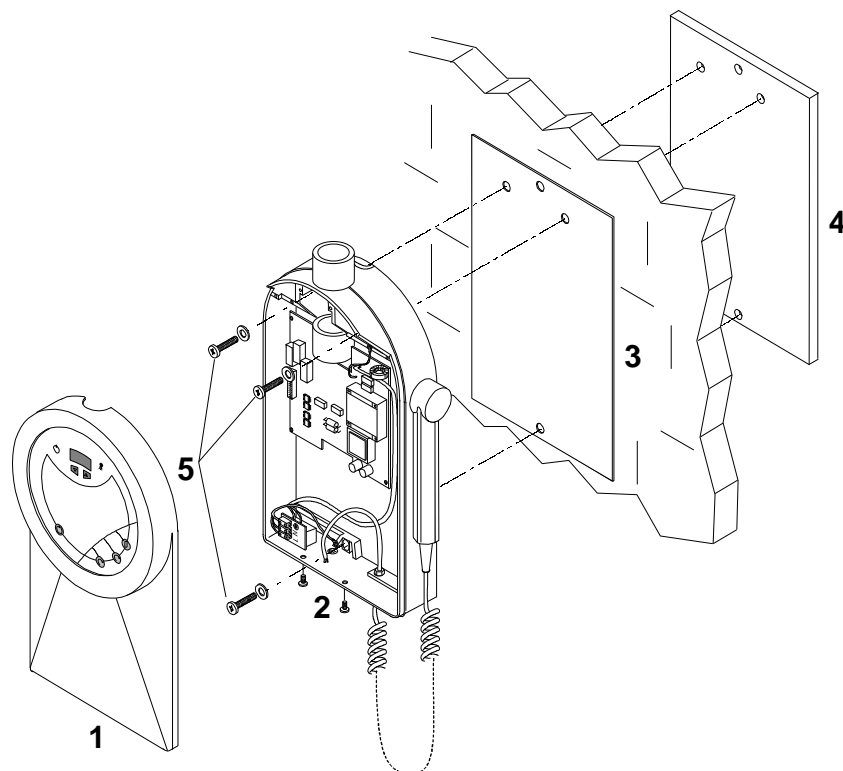
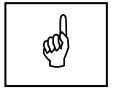

Figure 6-14

6.4.2 Remote X-ray button

**NOTE:**

Whatever remote X-ray button installation is implemented, the front panel of the timer must be visible from the remote button location to allow the user to see technical factors before starting an exposure.

There are two possible alternatives for remote X-ray button:

1. A door bell X-ray button can be installed following the instruction here below.

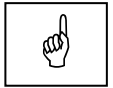
**NOTE:**

The connecting cable between Timer and Remote X-ray button, passing into the wall or external, must always be put into a metal conduct to avoid any kind of disturbance to the signals passing through the cable. The cable can be a maximum of 15 meters long and consequently the distance between Timer and X-ray button must be shorter than this length.

The connecting cable must have a 1mm² minimum section and must be connected to the X12 and X13 connectors on the logic board (CPU).

The remote X-ray button (not provided by Villa Sistemi Medicali) must be connected to the timer.

Safety regulations stipulate that a button enabled by an appropriate safety key must be used.

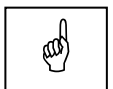
**NOTE:**

ENDOS AC/ACP is equipped with an exposure enabling key . In spite of this we suggest you set up an external X-ray button enabled by an appropriate safety device (key).

2. The kit P/N 6661309500 provides a way to install remotely a small group that resembles the front panel of the timer. This panel give also visibility of the status of the timer by two LED's signalling the "READY" and "EXPOSURE IN PROGRESS" status.

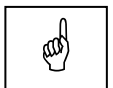
**NOTE:**

The connecting cable between Timer and Remote panel, passing through the wall or external must always be put inside a metal conduct to avoid any disturbance to the signals passing through the cable.

To install the cable inside the metal conduit, it is easy to start the insertion from the remote button location, inserting the female spade connector.

The cable provided in the kit must be used; each wire is labeled and must be connected to the proper spade connector of the logic board, so X12 to X12, X13 to X13 and so on.

The panel has to be fixed on the wall using the fisher type screws provided.

6.4.3 Installation of chemical screws

You are recommend to use chemical screws when installing the equipment on hollow bricks.

6.5 Electrical connection

**WARNING:**

For all versions, the tubehead must be connected to the supply board exactly as shown so that the equipment can deliver the nominal values. Connection errors give an abnormal absorption of current producing a slump in the tubehead performance and, in some cases, cause the line fuses to trip.

**NOTE:**

In Remote Timer version where you need to put a connecting extension (not supplied), **the maximum distances between timer and arm must be less than 12mt and the connecting cable must be 2.5mm² (14 AWG).**

6.5.1 Electrical connection for standard versions

1. Make the connection between the general switch and the terminal board of the timer using a bipolar cable plus ground, section 1.5 mm² (16 AWG), finishing off the cable towards the timer with the provided prod terminals. Fix the cable to the terminal board following the positions as shown (L = line, N = neutral, Ground = yellow/green cable). The conductors must be clamped to the timer base using the provided clip.
2. Connect the cable of the tubehead to the power board wiring the cables to the provided terminals and **following the positions as in the table:**

Tubehead wires colour	Tubehead wires identification	Power board position
Black	X3-L2	X3
Black or White	X4-N2	X4
Yellow/Green	Ground	Ground

X3-L2 e X4-N2 cables must be fastened together near the corresponding faston; moreover, it is necessary to prevent the same cables from passing between the two boards and as a consequence the surplus part of the cables must be secured to the top of the timer with a suitable loop.

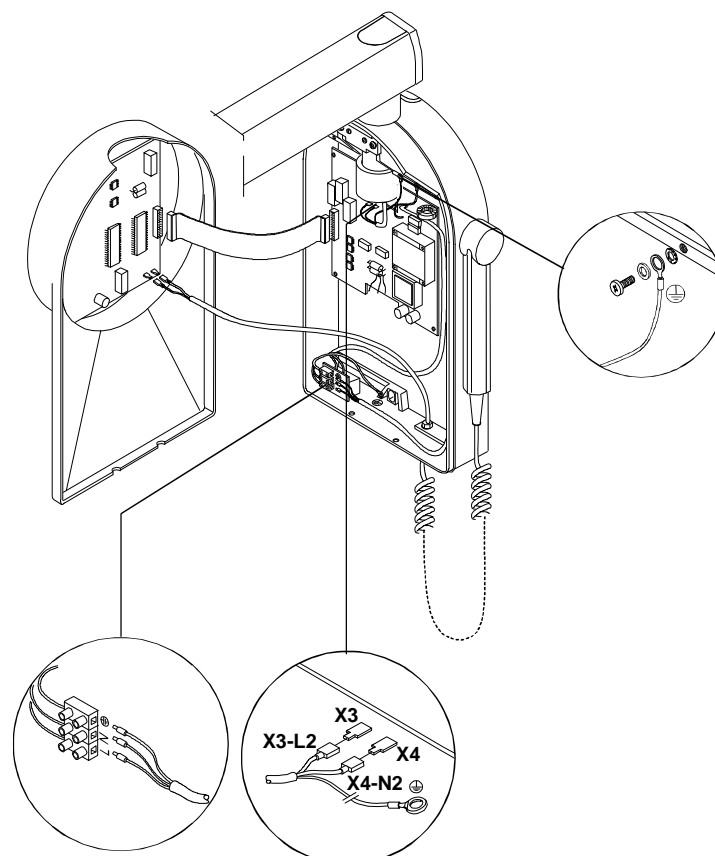

Figure 6-15

6.5.2 Electrical connection for versions equipped with Remote Timer

1. Make the connection between the general switch and the terminal board of the timer using a bipolar cable plus ground, section 1.5 mm² (16 AWG), finishing off the cable towards the timer with the provided prod terminals. Fix the cable to the terminal board following the positions as shown (L = line, N = neutral, Ground = yellow/green cable). The conductors must be clamped to the timer base using the provided clip.
2. Connect X3, X4 and Ground timer cables to terminal block X3, X4 and Ground respectively on wall support terminal block, using the terminals provided.
3. Connect tubehead cable to wall support terminal block, closing cables with relevant prod terminals provided and **following the position as in the table:**

Tubehead wires colour	Tubehead wires identification	Terminal block position
Black	X3-L2	X3
Black or White	X4-N2	X4
Yellow/Green	Ground	*

(*) Ground point of frame

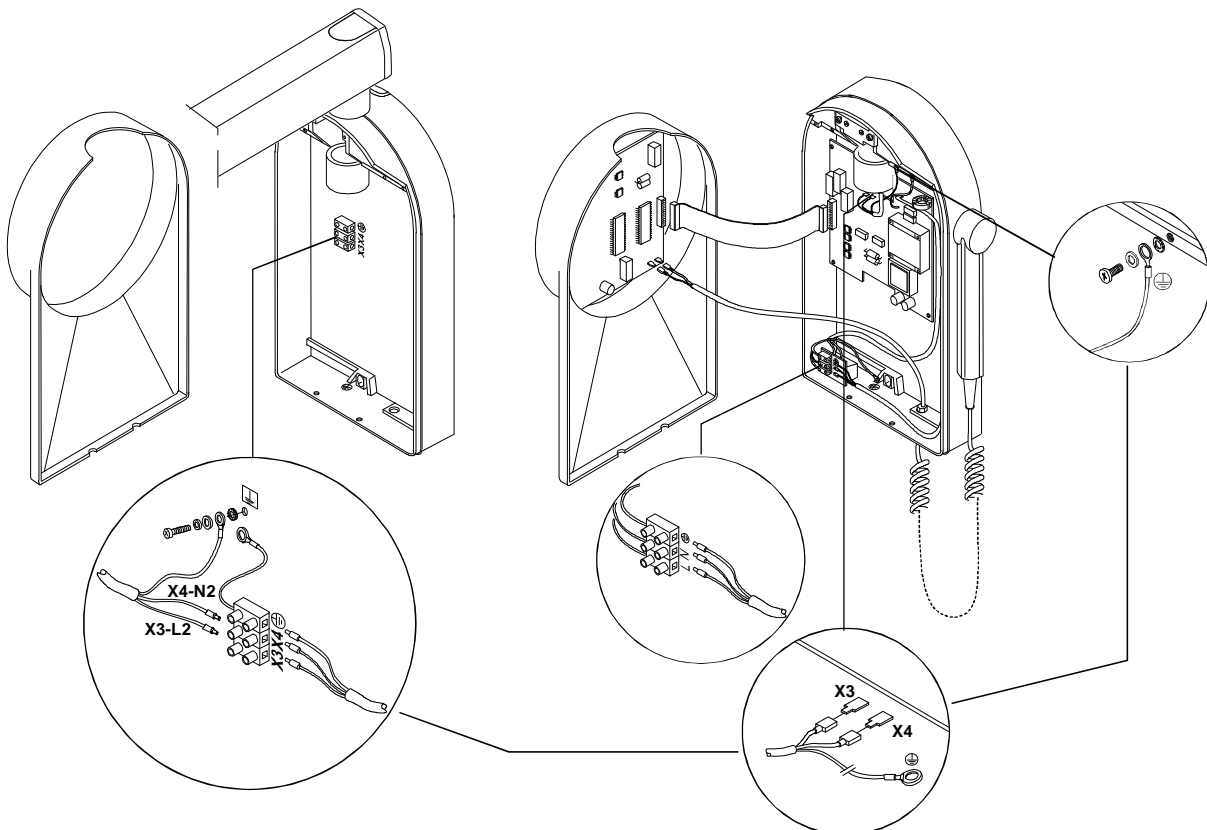

Figure 6-16

6.6 Final working tests

6.6.1 "ENDOS ACP" timer

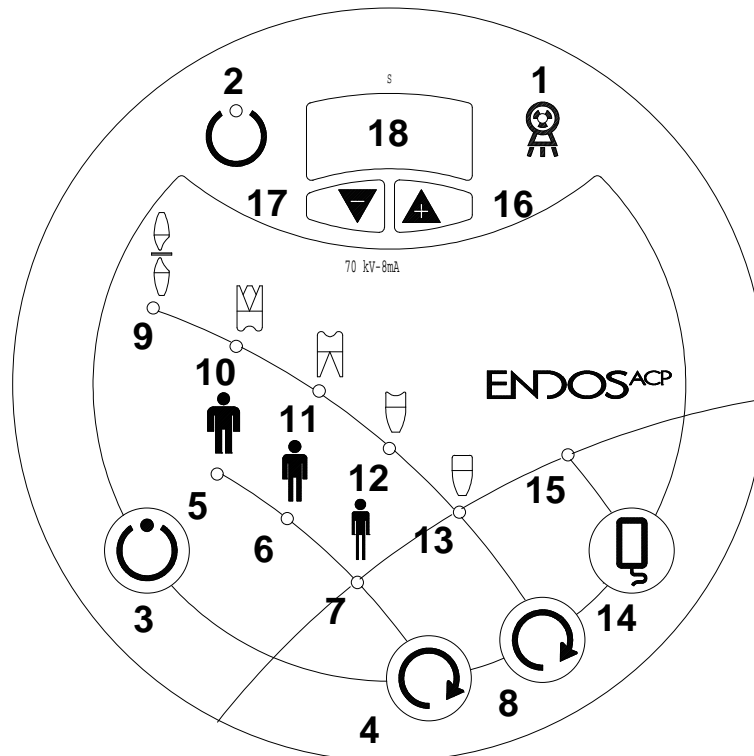

Figure 6-17: Control keyboard ENDOS ACP

- | | |
|-------------------------------------|------------------------------|
| 1 X-ray presence luminous indicator | 10 LED "Upper Molar" |
| 2 Green "Ready for X-ray" LED | 11 LED "Lower Molar" |
| 3 Exposure enabling "READY" | 12 LED "Premolars" |
| 4 Selection key "Size" | 13 LED "Incisors / Canines" |
| 5 "Large size" LED | 14 Videography selection key |
| 6 "Medium size" LED | 15 "Videography" LED |
| 7 "Small size" LED | 16 Increase key |
| 8 "Tooth anatomic" selection key " | 17 Decrease key |
| 9 LED "Bite-wing" | 18 Three figure display |

All functions in the equipment are set to standard values and tested in the factory during the final test. Some functions, however, can be adjusted by the Technical Service, only after setting up or according to particular needs (see chapter 8).

After connecting the equipment to the line voltage, make the following functional tests:

1. Turn the line switch placed in the lower part of the timer to **ON** and check that the switch light comes on.
2. Check the correct working in automatic mode checking with all Size/Type of tooth combinations that the values on the display correspond to the values in the table. The values in the table are those shown when the multiplication factor "1" (see set up parameter P13 paragraph 8.1) is set.

These suggested values are for type "D" film. For other films, please refer to film manufacturer specification.











			
	0.25	0.32	0.50
	0.36	0.63	0.80
	0.32	0.50	0.70
	0.32	0.50	0.70
	0.25	0.32	0.50

Table 1

3. Select manual function by (increase)  or (decrease) 

key and check, pressing the keys repeatedly, that the display shows the different manual exposure times as in the following table:



<p>0.02 - 0.04 - 0.06 - 0.08 - 0.10 - 0.12 - 0.14 - 0.16 - 0.18 - 0.20 - 0.23 - 0.25 - 0.30 - 0.32 - 0.36 - 0.40 - 0.45 - 0.50 - 0.54 - 0.60 - 0.63 - 0.70 - 0.80 - 0.90 - 1.00 - 1.25 - 1.30 - 1.40 - 1.60 - 2.00 - 2.50 - 3.00 - 3.20</p>
--

Table 2



WARNING:

The following test involves X-ray emission; all the safety precautions stipulated by local safety regulations must be followed.

4. Put a fluorescent screen (not provided), to display the radiation, at the end of the collimator, press key  and check simultaneous start-up of the green indicator  , press the X-ray button and check the simultaneous start-up of the luminous indicator  and the production of the acoustic signal for X-ray emission.



NOTE:

When pressing the "READY" key, the system not only enables exposure but it will also start displaying on the display the exposure time calculated according to the compensation of fluctuations of the line voltage (see paragraph 4.1).

If these tests are positive, **THE EQUIPMENT IS READY FOR USE.**

6.6.2 "ENDOS AC" timer

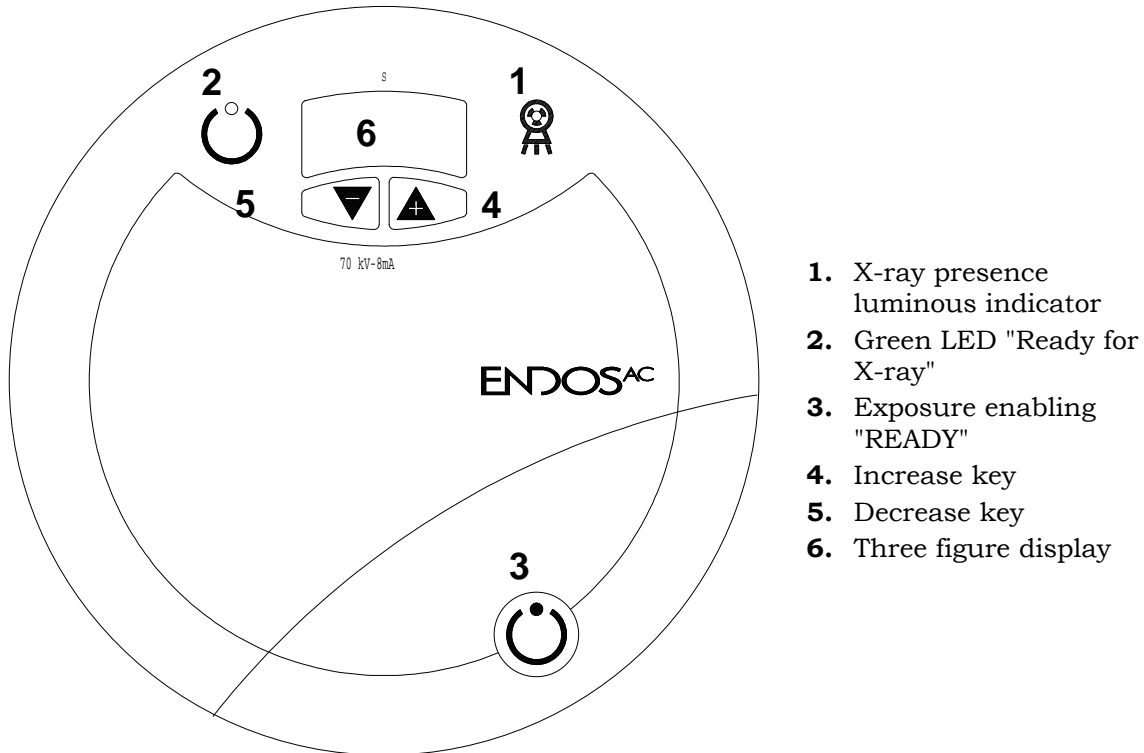



1. X-ray presence luminous indicator
2. Green LED "Ready for X-ray"
3. Exposure enabling "READY"
4. Increase key
5. Decrease key
6. Three figure display

Figure 6-18: Control keyboard ENDOS AC

All the functions of the equipment are set to standard values and tested in the factory during the final test. Some functions however can be adjusted, by Technical Service, only after setting up or according to particular needs (see chapter 8).

After connecting the equipment to line voltage, perform the following functional tests:

1. Turn the general switch placed in the lower part of the timer to **ON** and check that the switch light comes on and the control panel is activated.

2. By key  (increase) or  (decrease) check that the display shows the different manual exposure times as in the following table:



<p>0.02 - 0.04 - 0.06 - 0.08 - 0.10 - 0.12 - 0.14 - 0.16 - 0.18 - 0.20 - 0.23 - 0.25 - 0.30 - 0.32 - 0.36 - 0.40 - 0.45 - 0.50 - 0.54 - 0.60 - 0.63 - 0.70 - 0.80 - 0.90 - 1.00 - 1.25 - 1.30 - 1.40 - 1.60 - 2.00 - 2.50 - 3.00 - 3.20</p>
--

Table 3



WARNING:

The following test involves X-ray emission; all the safety precautions stipulated by local safety regulations must be followed.

3. Put a fluorescent screen (not provided), to display radiation, at the end of the collimator, press key  and check simultaneous start-up of the green LED , press the X-ray button and check simultaneous start-up of the luminous indicator  and the production of the acoustic signal of X-ray emission.



NOTE:

When pressing the "READY" key, the system not only enables exposure but it will also start displaying on the display the exposure time calculated according to the compensation of fluctuations of the line voltage (see paragraph 4.1).

If all these tests are positive, **THE EQUIPMENT IS READY FOR USE.**

7. MAINTENANCE

7.1 Generalities

Like all electrical equipment this unit requires not only correct use, but also regular maintenance and checks. This precaution will guarantee that the equipment works safely and efficiently.

Periodic maintenance consists of checks performed directly by the operator, and/or by Technical Service.

The following checks are performed directly by the operator:

- Check that labels are intact and fixed on well
- Check that there is no oil leaking on the tubehead
- Check that the X-ray button cable is not broken or scratched
- Check that there is no external damage which might jeopardise the safety of the protections against X-rays
- Check the centering of the X-ray beam
- Check the balance of the scissors arm.



WARNING:

The operator must inform Technical Assistance immediately if there are any irregularities or damage.

In order to keep the initial features of the equipment, we recommend a general overhaul once a year by a Technician authorised by Villa Sistemi Medicali.

In addition to the checks listed above, the Service technician may also perform checks on:

- The adjustment of extension and DP arm frictioning mechanism
- The adjustment of the DP arm balance springs, if necessary.



WARNING:

Only technicians authorised by the Manufacturer are allowed to carry out adjustment during maintenance operations.

7.2 Arm adjustment

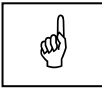

NOTE:

It is not necessary to dismantle the tubehead to adjust the arms. If you think that this operation is useful or necessary, before removing the tubehead put the scissors arm in the closed position and tie it up using the safety clamp to prevent harming people or the arm itself.

The arms may need adjusting in the following cases:

- the movement of the extension arm combined with the scissors arm is not considered to be ergonomic by the end user; in this case it will be necessary to adjust the extension arm frictioning mechanism.
- the scissors arm is not perfectly balanced; in this case you must adjust the springs.

7.2.1 Adjusting the extension arm support frictioning mechanism

The device to adjust the arm support frictioning mechanism is placed on the front of the wall support. To make this adjustment you must proceed as follows.

1. Remove the plastic timer cover by loosening the two sealing screws placed on the lower part of the wall plate. Lift the plastic cover from the bottom and push it upwards to release it from the upper stops. Be careful not to disconnect the connecting cables.
2. Using a 7 mm wrench, adjust the frictioning mechanism nuts (**1**) until the movement of the arm is ergonomic.
3. Reposition the plastic cover when you have finished.

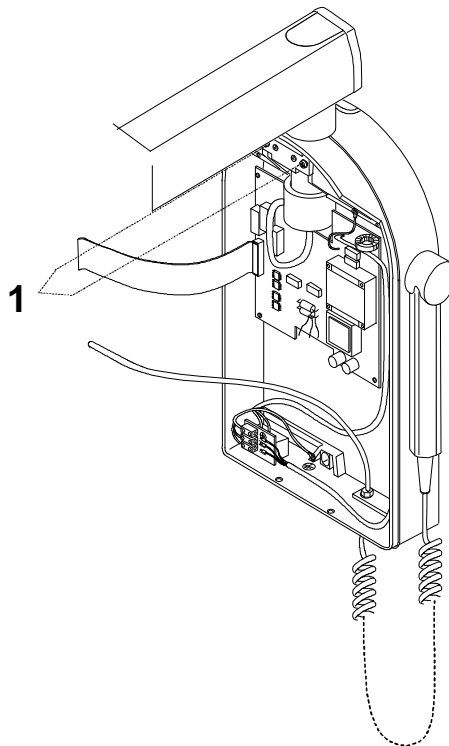
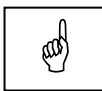

Figure 7-1

7.2.2 Adjusting the extension arm frictioning mechanism

1. Remove the small front extension arm cover, working carefully.
2. Adjust the frictioning mechanism (**1** - Figure 7-2) using a 5 mm hexagon wrench checking the rotation of the scissors arm.



NOTE:

The purpose of this frictioning mechanism is to prevent the scissors from becoming detached, so it must not be loose.

3. Assemble the cover again.

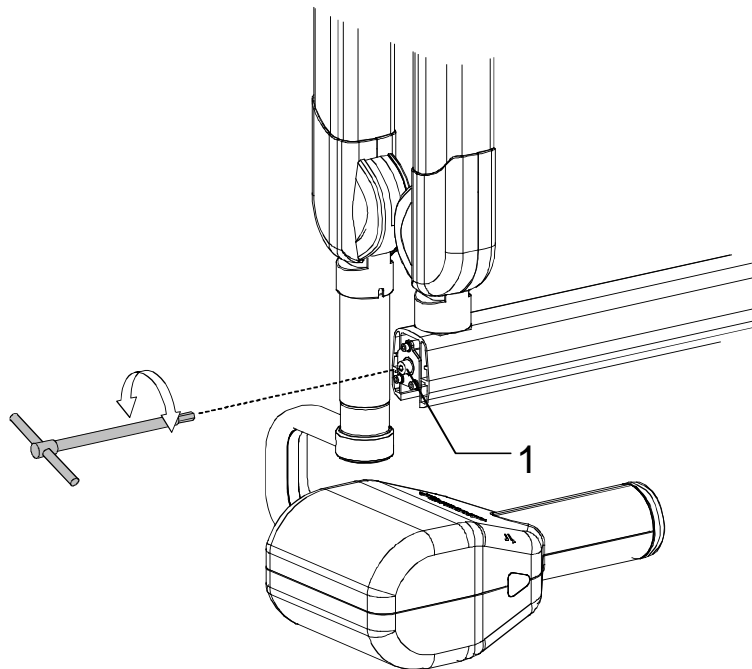

Figure 7-2

7.2.3 Adjusting the balance scissors arm

- **Adjusting the second arm**

Proceed as follows to adjust the scissors arm:

- **Adjusting the friction (for small corrections - picture A)**
 1. Put the arm in a horizontal position; remove the plastic coordinator covers. **This must be done carefully to avoid breaking the covers themselves.**
 2. Using a 2.5 mm hexagon wrench, loosen the dowel (1).
 3. Using two 13 wrenches, adjust the frictioning mechanism by rotating one of the wrenches $\frac{1}{4}$ of a turn each time.
 4. When you have finished the adjustment, tighten the previously loosened dowel and reassemble the plastic covers.

- **Adjusting the spring (picture B)**

If adjustment of the friction is not enough, you can adjust the spring to optimise the balance:

- 1 Put the arm in a horizontal position; remove the plastic coordinator covers. **This must be done carefully to avoid breaking the covers themselves.**
- 2 Insert a 6 mm hexagon wrench (about 200mm long – contained in the kit P/N 6661209900). **This wrench must rotate clockwise if the arm tends to go down compared to the release position; anticlockwise if it tends to go up.**
- 3 When you have finished the adjustment, reposition the plastic covers.

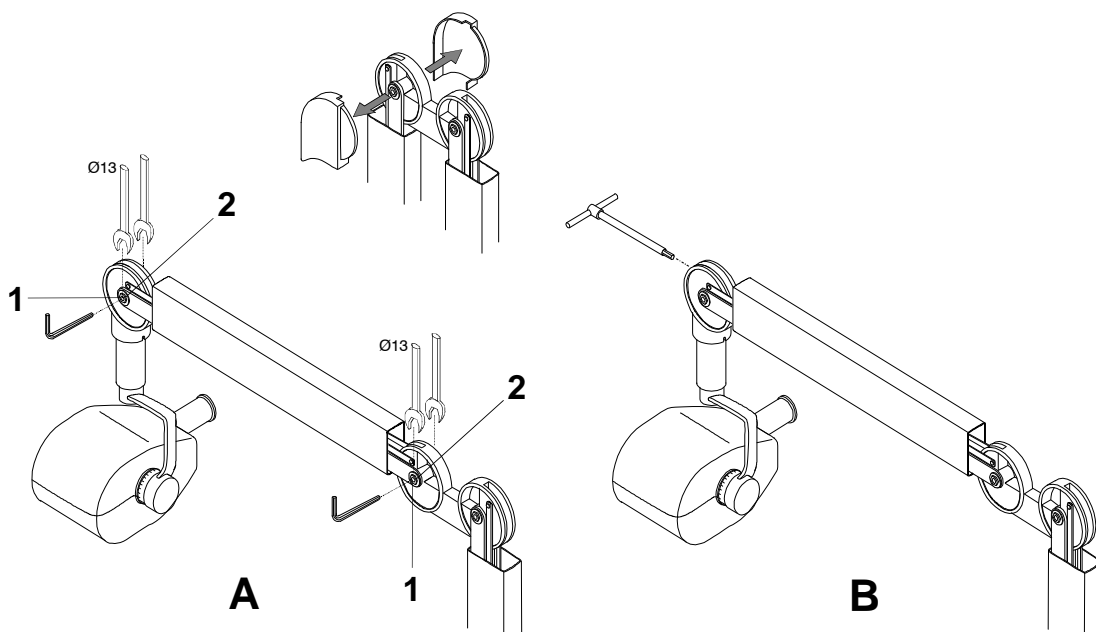

Figure 7-3

- **Adjusting the first arm**

If the first arm also needs to be adjusted:

- **Adjusting the friction (for small corrections - picture A)**

- 1 Close the arm scissors arm; remove the plastic co-ordinator covers. **This must be done carefully to avoid breaking the covers themselves.**
- 2 Using a 2.5 mm hexagon wrench, loosen the dowel (1).
- 3 Using two 13 wrenches, adjust the frictioning mechanism by rotating one of the wrenches $\frac{1}{4}$ of a turn each time.
- 4 When you have finished the adjustment, tighten the previously loosened dowel and reassemble the plastic covers

- **Adjusting the spring (picture B)**

If adjustment of the friction is not enough, you can adjust the spring to optimise the balance:

1. Put the arm in a horizontal position; remove the plastic co-ordinator covers. **This must be done carefully to avoid breaking the covers themselves.**
2. Insert a 6 mm hexagon wrench (about 200mm long – contained in the kit P/N 6661209900). **This wrench must rotate clockwise if the arm tends to go down compared to the release position; anticlockwise if it tends to go up.**
3. When you have finished the adjustment, reposition the plastic covers

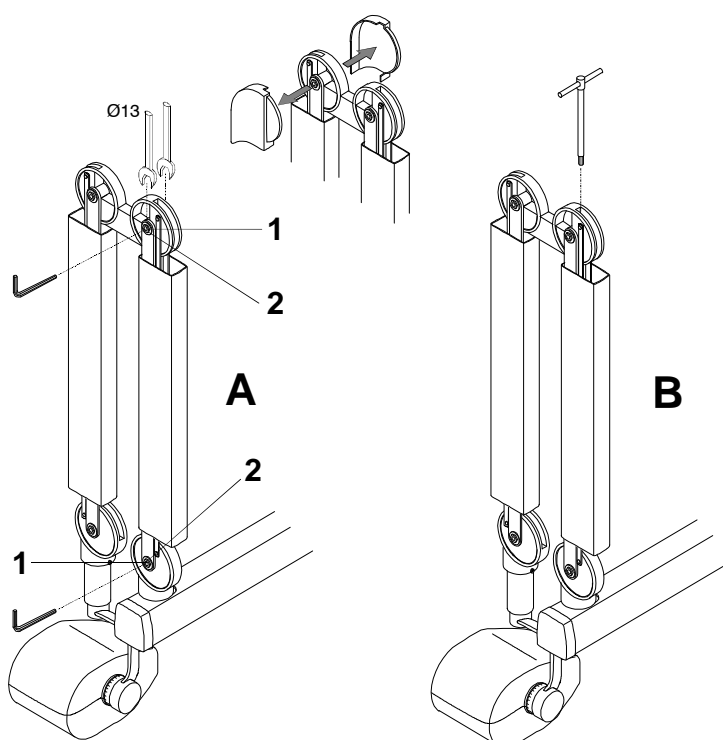

Figure 7-4



8. SET-UP

When replacing the timer electronics or the tubehead, ENDOS AC/ACP requires an updating of the configuration parameters, achieved by carrying out the "PARAMETER SET-UP" procedure.

**NOTE:**

During the SET-UP procedure, the LEDs of the keyboard are not activated.

Starting from OFF STATUS, switch the unit on pressing the main switch (I/O) on the lower part of the timer and wait completion of the initial check procedure. While the system displays

the software version (for instance 4.00), press simultaneously keys "increase"  and "decrease"  for about 5 seconds,

until the words **"Pr0"** are displayed for about 2 seconds.

After 2 seconds the words **"Pr0"** disappear and the first programmable parameter **"P01"** is shown on display.

**WARNING:**

During each step of the Set-up procedure, storage of the selected parameter is carried out by pressing the key "System enabling" .

After pressing this key, the system stores the current displayed value and moves to the next parameter to be edited.

**NOTE:**

The change made to the selected parameter must be confirmed within 5 seconds of selection and the change of the parameter itself. If the change is not confirmed during this period the system will return to the phase previous to the change itself (without storing the changed value), displaying again the number of parameter that must be checked / edited. This condition is shown by the letters "PXX".

Within the Set-up program, the procedure to access and edit the value of the selected parameter is the following:

1. When the display shows the message "**Pxx**" press one of the keys "increase" or "decrease" to activate editing of the parameter.
2. To edit the selected parameter, press one of the two keys "increase" or "decrease" again until the display shows the requested value of the parameter itself.

Example: selection of the line voltage

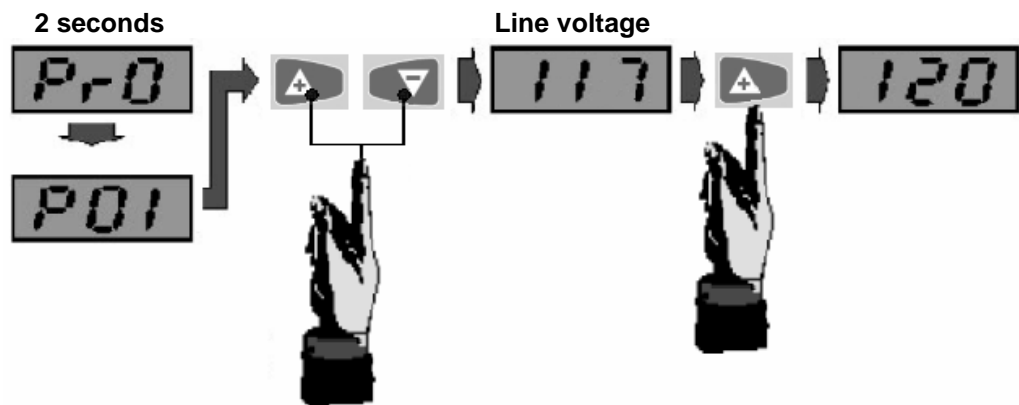

If only one or a few parameters must be modified, press more times key  until the parameter you want to modify is displayed, without selecting any value of the intermediate parameters.

- Example:**
- 1) **Activation of the cooling break (P09)**
 - 2) **Correction factor film sensitivity (P13).**

The two following pages show the sequence of actions necessary to modify the programming of the two parameters P09 and P13, without displaying the other parameters (QUICK PROGRAMMING SEQUENCE).



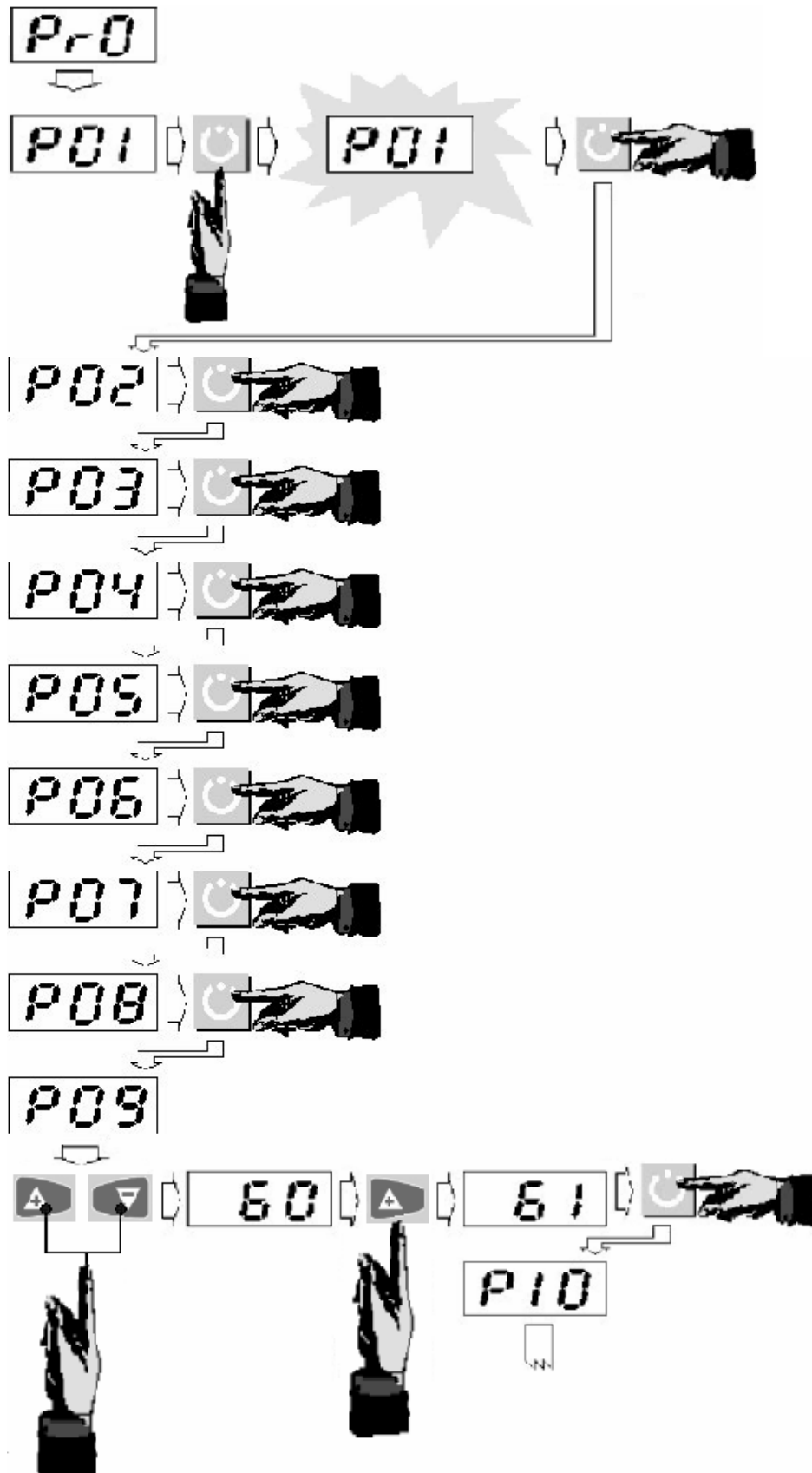

it continues on the following page

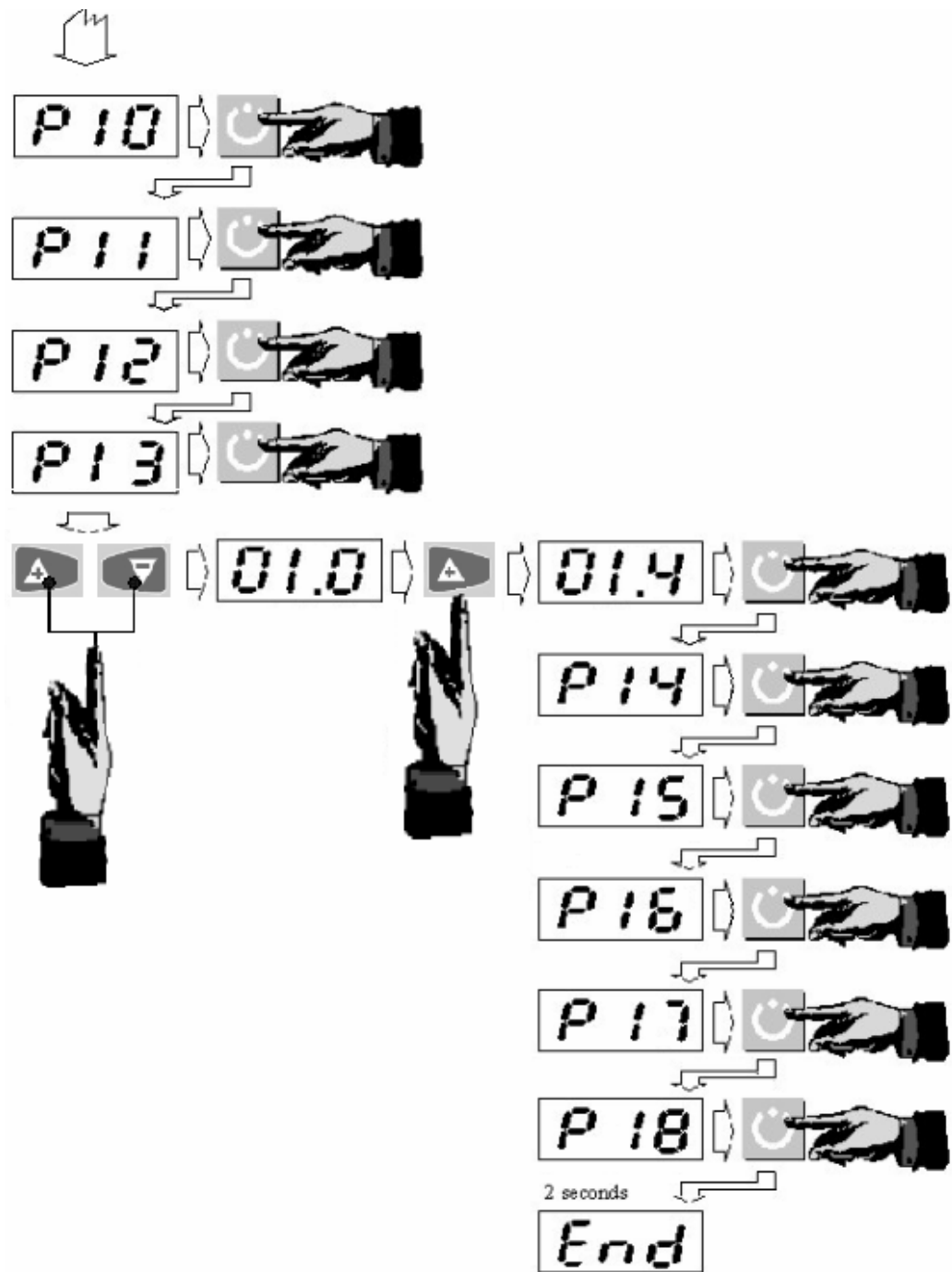

8.1 Display and modification of parameters

P01 Selecting line voltage:

The selected value in this section is useful only as an internal reference for the correction of the exposure time according to the variation of line voltage. The selectable values are: 115Vac, 120Vac, 220Vac, 230Vac and 240Vac; always make sure that the selected value corresponds to the value of the system voltage supply as specified in the labels.

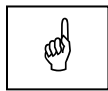

NOTE:



When the selected value of the line voltage does not correspond to the value shown on the identification label of the system, the system itself cannot be defined as complying with CE 93/42 Regulation.

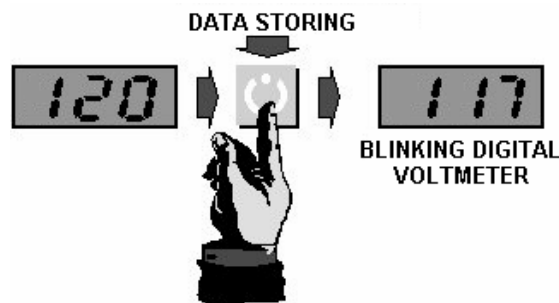

After making the suitable selection, if necessary, press button  ;

in this case (**P01**), after pressing the button, the display will show, intermittently, the value of the line voltage currently read by the internal voltmeter (precision $\pm 1.5\%$); in this way the system enables the operator to verify possible fluctuations in the line voltage.



The following operations make it possible to calibrate the value read by the voltmeter inside the timer, using a digital multimeter (DVM):

1. Connect a digital voltmeter (DVM), which can measure actual RMS values, to the supply line entry connector and select it to read in alternate voltage (AC).
2. Press simultaneously keys  and  for at least two seconds. This operation resets any offset values already in the system to zero.

3. Press one of keys  and/or  so that the readings of the two voltmeters (the internal one to the system and DVM) are the same.
4. When the requested value is reached, press button  to confirm the datum. At this point the display will go to the second step of the set-up procedure, displaying the message "**P02**".

P02 Selecting the tubehead supply method:

Parameter not to modify.

The value must be [**P=1**].



NOTE:

Selecting a different value from the one shown will change the working conditions of the system and relevant selection data. For this reason parameter "**P02**" must not be changed.

Press button  to proceed to the following step.

P03 Pre-heating time:

This parameter is reported on the label of the tubehead: it is important to verify that the value in set-up is exactly the same reported on the tubehead label.

The default value is [**0.10**] (seconds).



NOTE:

In order to guarantee that the system functions correctly and observation of CE 93/42 Regulations, parameter "**P03**" must be the value reported on the tubehead label a pre-heating time.

Press button  to proceed to the following step.

P04 **Booster Time:**

Parameter not to be changed.

The value must be [**0.04**].

**NOTE:**

Selecting a different value from the one shown will change the working conditions of the system and relevant selection data. For this reason parameter "P04" must not be changed.

Press button  to proceed to the following step.

P05 **Minimum exposure time:**

This selection allows the choice of the minimum exposure time expressed in seconds. The minimum exposure time can be chosen from the following times:

0.02 / 0.04 / 0.06 / 0.08 / 0.10 / 0.12 / 0.14 / 0.16 / 0.18 / 0.20

The minimum exposure time is [**0.02**] (seconds).

Press button  to proceed to the following step.

P06 **Maximum exposure time:**

This parameter makes it possible to limit the value of the maximum exposure time settable by the user, up to a value of 2 seconds.

- selecting [**E=0**] all exposure times shown in the following table are settable by the operator
- selecting [**E=1**] the maximum exposure time value is 2 seconds.

0.02 - 0.04 - 0.06 - 0.08 - 0.10 - 0.12 - 0.14 - 0.16 - 0.18 - 0.20 - 0.23 -
0.25 - 0.30 - 0.32 - 0.36 - 0.40 - 0.45 - 0.50 - 0.54 - 0.60 - 0.63 - 0.70 -
0.80 - 0.90 - 1.00 - 1.25 - 1.30 - 1.40 - 1.60 - 2.00 - **2.50** - **3.00** - **3.20**

Press button  to proceed to the following step.

P07 **Selecting the compensation factor value of exposure times:**

This parameter must be selected according to the nominal value of the line voltage as in the following table:

Line voltage	P7
120V	005



NOTE: To guarantee compliance with CE 93/42 Regulation, the selected value must conform to the one defined above.

Press the button  to proceed to the following step.

P08 **Selecting the compensation factor of pre-heating time:**

This parameter must be selected according to the nominal value of line voltage as in the following table:

Line voltage	P8
120V	001

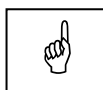

NOTE: To guarantee compliance with CE 93/42 Regulation, the selected value must conform to the one defined above.

Press button  to proceed to the following step.

P09 Tubehead cooling time:

This is the value of parameter K (value selectable between 0 and 80) which, multiplied by the current value of exposure time, calculates the value of the cool down time between consecutive exposures.

$$\text{COLL DOWN BETWEEN EXPOSURES} = \text{Exposure time} \times \text{K}$$

The preset time is [32] (thirty-two times the exposure time).

**NOTE:**

To give the tubehead an adequate cooling time, the minimum time to select is 32. Values different from the value shown can reduce the life of the tubehead and will also result in non compliance of the system to CE 93/42 Regulation.

Press button  to proceed to the following step.

P10 Time between system enabling and exposure:

This is the maximum time (in seconds) available to the operator between enabling (obtained pressing key ) and starting the exposure.

This parameter varies from 10 to 30 seconds (1 second a step).

The preset value is [15] seconds and can be modified using the "increase" or "decrease" keys.

Press button  to proceed to the following step.

P11 Selecting the tubehead version:

Parameter not to be changed.

This value makes it possible to select the suitable value according to the high voltage value of the connected tubehead.

The preset value is [**70**] (ENDOS AC/ACP).



NOTE:

To guarantee compliance with CE 93/42 Regulation, the selected value must conform to the one defined above.

Press button  to proceed to the following step.

P12 Enabling digital radiology:

This selection makes it possible to activate "digital X-ray" mode which, if enabled, automatically selects reduced exposure times, useful in the digital mode.

This reduction is used together with key .

The "digital X-ray" selection mode is [**d=0**] disabled, so touching the digital key described above does not produce any effect.

On the contrary, if you select [**d=1**], the "digital X-ray" mode is activated. After making this selection, the system will adjust the exposure time of Anatomic selections to the digital acquisition mode, multiplying the exposure time set for type D film by "**P14**" factor.

Press button  to proceed to the following step.

P13 Correction factor for film sensitivity:

This parameter adapts the exposure times associated to Anatomic and Size selections to the film speed used by the user.
The parameter "**P13**" multiplies the set time for type D film.
The available values are shown in the following table:

0.2 / 0.4 / 0.5 / 0.6 / 0.8 / 1.0 / 1.4 / 1.6 / 2.0
--

The set value must be chosen according to the film manufacturer suggestions.

The default factor is **[1.0]**.

The factor can also be changed by the user following the relevant procedure described in the User Manual.

Press button  to proceed to the following step.

P14 Correction factor for Digital X-rays:

This parameter adapts exposure times associated to Anatomic and Size selections to digital acquisition modes, pressing key .

The parameter "**P14**" multiplies the time set for type D film.
The available values are shown in the following table:

0.1 / 0.15 / 0.2 / 0.25 / 0.30 / 0.40
--

The default factor is **[0.2]** that is the multiplying factor of the exposure time for D-type film.
Changes must be performed according to the sensor used.

The factor can also be modified by the user following the relevant procedure described in the User's Manual.

Press button  to proceed to the following step.

P15 Selection of manual exposure base time:

This selection (no more significant in the current software release) sets the default value of nominal exposure time.

Leave the default configuration.

Press button  to proceed to the following step.

P16 Zero setting of the exposure counter:

This operation resets the internal exposure counter to zero. As a first step, the system displays the figures relevant to "thousands", then it displays the figures relevant to values from 0 to 999.

To reset the counter, proceed as follows:

1. Press the exposure button and check that the displayed number on the display flashes.
2. Within 5 seconds, press the exposure button again and check that the display stops flashing and the figures displayed are "000": This shows that the figures of the thousands have been set to zero.
3. Press the "decrease" button and repeat the above procedure for the other figures.

Press button  to proceed to the following step.

P17 Enabling/Disabling the "READY" button:

The value of the parameter must be [**A=1**] "READY" button enabled. If P17 is configured at "0" the exposure enabling is prevented and the system is always ready for emission: the "ready for X-ray" LED is always on.

**NOTE:**

When the "Ready" button is disabled, the display will show the "corrected exposure" time (see paragraph 4.1) only during exposure or holding the X-ray button pressed at the end of it.

Press button  to proceed to the following step.

P18 Last exposure time storage:

This selection enables/disables storage of the last Anatomic and Size selection or of the exposure time executed.

***r=1** = stores the last exposure time.

***r=0** = does not store the last exposure time.

Press "increase" and "decrease" button to select the requested value.

If you select **r=1** when switching the system on again, the last selected time before switching off the equipment appears.

Press button  to stop set-up operations.

The following table displays the values of the programmable parameters

Display	Parameters	Set Value	WARNING
P01	Selection of line voltage	120	
P02	Selection of the tubehead supply mode	P=1	(1)
P03	Pre-ignition time	derived from label on tubehead	(1)
P04	Booster time	0.04	
P05	Minimum exposure time	0.02	
P06	Maximum exposure time	E=0	
P07	Selection of compensation exposure time	005	(1)
P08	Selection of compensation pre-ignition time	001	(1)
P09	Selection of break factor	32	(1)
P10	Time between activation "Ready" and exposure	15	
P11	Selection of high voltage value tubehead	70	(1)
P12	Digital radiography enabling	d=1	
P13	Correction factor film sensitivity	1.0	
P14	Correction factor for Digital Radiography	0.2	
P15	Selection of base value of exposure time	0.30	
P16	Zero setting of exposure meter	////////	
P17	Enabling of "Ready" button	A=1	
P18	Last exposure time storage	r=1	



WARNING:

Parameters marked with **(1)** in the following table cannot be changed; if any changes are made there is no guarantee that the system will function correctly or that it will comply with CE 93/42 Regulations.

9. ERROR MESSAGES AND TROUBLESHOOTING

ENDOS AC and ENDOS ACP timers are provided with a self diagnostics function which constantly monitors the system and its most important safety circuits.

In a problem occurs, the system displays an error message, to inform the operator. Three different groups of alert messages displays are provided:

- errors found during the start-up phase requiring the intervention of technical assistance
- errors found during start-up phase which, since they do not concern safety factors, can be reset. These do not require the prompt intervention of technical assistance
- errors found during the X-ray exposure.

The first of these three error types, found during start-up phase, disables the system so to avoid any action. The disabling status can be reset only by switching the system off and on again or by following the instructions described in the following pages. The codes corresponding to the error messages range from “**E01**” to “**E09**”.

Error conditions which can be reset may affect some unimportant system functions, while still leaving others possible. The codes corresponding to the error messages range from “**E11**” to “**E12**”.

Failure conditions found during X-ray exposure phase can take the system to a condition where a following exposure is not allowed. This type of error is shown by messages ranging from “**E20**” to “**E25**”.

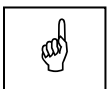
**NOTE:**

Isolated error message signals (ex. Signals changing each time) can be caused by false contacts on the flexible connection cable between the CPU board and power board. Check that the flexible cable connecting the X1 power board connector to the corresponding X4 connector of the logic board (CPU) is connected correctly and functions well, checking the total connection. Replace the cable if necessary.

9.1 Functional messages

- **Line voltage lower than 12.1%**

Before exposure, the system measures the supply line voltage and compares it to the value of the rated voltage. If this value is lower than 12.1%, the display will show message "LLL" and the green LED "Ready" will start flashing simultaneously. To reset the condition, press the "INCREASE" or "DECREASE" button.

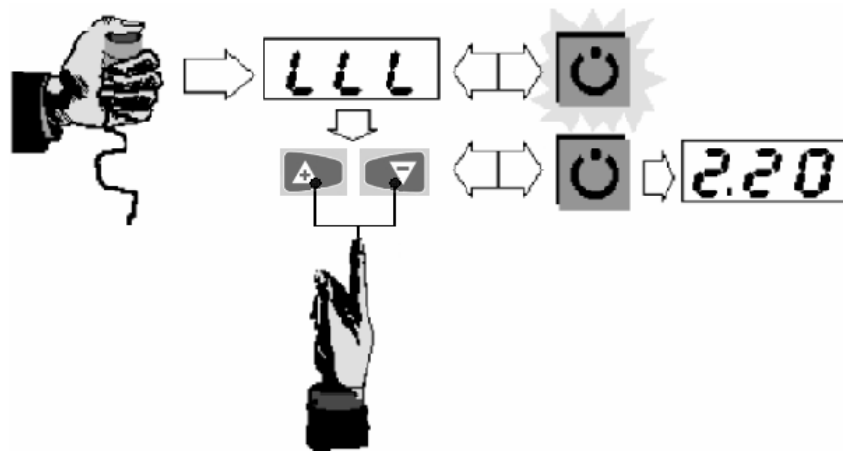

- **Line voltage higher than 12.1%**

Before executing X-ray emission, the system measures the supply line voltage and compares it to the value of the rated voltage. If this value is higher than 12.1%, the display will show message "HHH" and the green LED "Ready" will start flashing simultaneously. To reset the condition, press the "INCREASE" or "DECREASE" button.

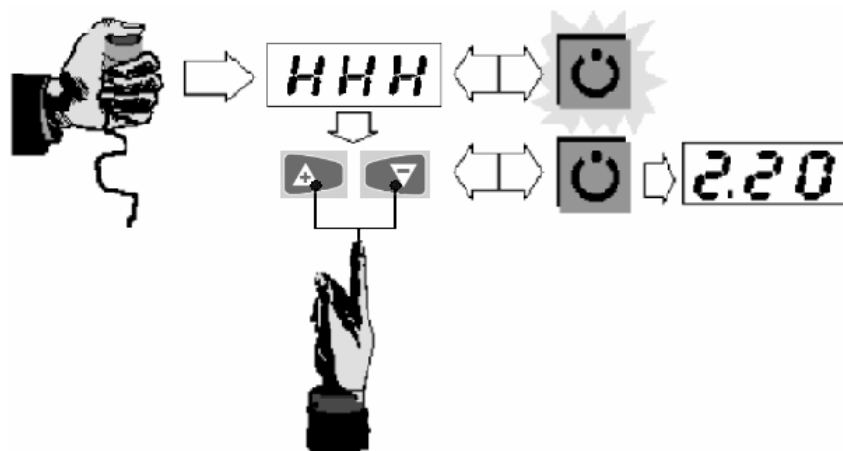

- **Exposure time of more than 4 seconds**

In the enabled status, the system calculates the correct exposure time value to compensate fluctuations in line voltage. If the time calculated in this way is greater than 4 seconds value, the display will show the thus calculated value (for instance 4.20 seconds) and the green LED "Ready" will start flashing without exposure occurring. To reset this condition, press the "INCREASE" or "DECREASE" button.

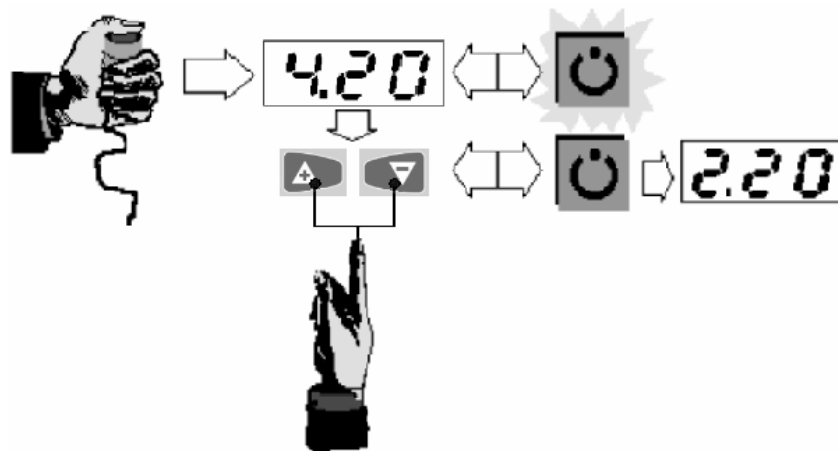
**NOTE:**

In the event of a serious anomaly in the control system, exposure is stopped after a maximum of 5.5 seconds and the corresponding error signal is given.

- **X-ray button released before exposure end**

The X-ray emission button is a "dead man" control; so it must be held pressed during the whole exposure. If the button is released before the exposure ends, the emission is automatically stopped; this situation is shown on the display by the flashing message "E P", and the luminous signals on the keyboard will be off. To reset this condition, press "increase" or "decrease": the green LED will start blinking without exposure and the tube cooling time countdown will be shown. When the cool down is over the device goes back to the IDLE state.

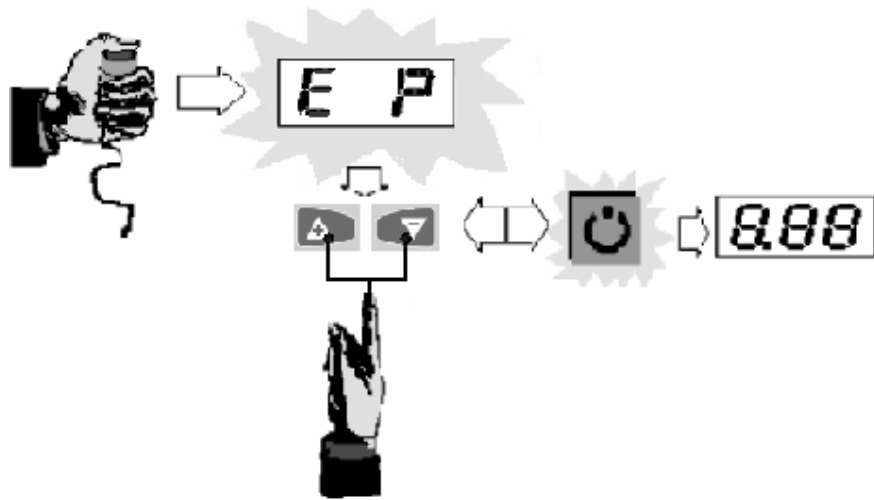

NOTE:

Before starting a new exposure, replace the film to avoid a double exposure with meaningless diagnostic results.

9.2 Errors during start-up phase



WARNING:
THE TWO TIMER BOARDS, CPU AND POWER ARE MATCHED IN THE FACTORY. DO NOT REPLACE ONLY ONE OF THESE BOARDS SINCE THIS COULD AFFECT ON HOW THE SYSTEM FUNCTIONS.

DISPLAY signalling	ANOMALY type	Checks and operations to execute
CHS	Checksum error of memories (EEPROM + EPROM) or RAM test (1)	This means there is a serious error in the system memories, so data may not be valid. <ul style="list-style-type: none"> Switch the system off and switch it on again, pressing button "Ready" and X-ray button together. This operation resets the system to pre-set values If the error condition remains, replace the two timer boards. NOTE: After a reset, you must execute a full system set-up.
E01	X-ray relay closed at start-up	Serious failure of safety devices. Check the possible disconnection of the flexible cable between the two boards or its correct connection. If the cable is broken or damaged, replace it; otherwise replace the two timer boards.
E02	Tubehead supplied during start-up	Switch the system off immediately, as X-ray emission may be present. Check the possible disconnection of the flexible cable between the two boards or its correct connection. If the cable is broken or damaged, replace it; otherwise replace the two timer boards.
E03	X-rays button "Main" X-ray button closed at start-up	Check if the X-ray button is closed and replace it if it is; otherwise replace the two timer boards.
E04	"Remote" X-ray button closed at start-up	Check if the X-ray button is closed and replace it if it is; otherwise replace the two timer boards.
E05	Both X-ray buttons closed at start-up	Check if both X-ray buttons are closed and replace them if they are; otherwise replace the two timer boards.
E06	"Ready" button pressed at start-up	<ul style="list-style-type: none"> Check that the keyboard cable is perfectly connected to the X1 logic board connector. The flexible cable must be connected to the connector of the logic board nearest to the board itself, while the short connector must be connected so that it ends at pin 31. Replace keyboard if necessary. Replace the two timer boards if necessary.

DISPLAY signalling	ANOMALY type	Checks and operations to execute
E07	"Digital Mode" Button (DIX) pressed at start-up (3)	The same as error E06 above.
E08	"Increase" button pressed at start-up	The same as error E06 above.
E09	"Decrease" button pressed at start-up	The same as error E06 above.

9.3 Errors that can be reset during the start-up phase

During the start-up phase the system executes a series of tests to ensure that the equipment is functioning correctly; if, during this phase, conditions that do not concern timer safety factors are found, the timer itself may continue working even with reduced functions. The error signal is displayed on the display until either the "Increase" or "Decrease" key is pressed and all error conditions have been displayed. This operation brings the system into IDLE-ON condition and the display will show the default exposure time.



NOTE:

If more errors have been found in the same phase, the errors can be displayed in sequence by pressing the "Increase" or "Decrease" key. The system will reach the working condition (IDLE-ON) after displaying the last error message.

EXAMPLE:

SIZE selection and TOOTH ANATOMIC selection pressed during the start-up phase will give the following display:

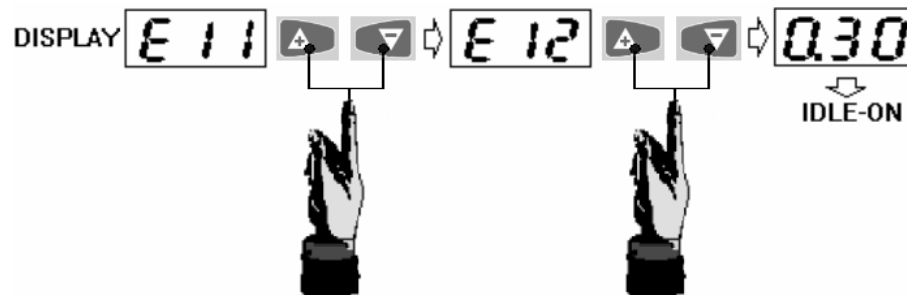

DISPLAY signalling	ANOMALY type	Checks and operations to execute
E11	"PATIENT'S SIZE" key pressed at start-up	<ul style="list-style-type: none"> • Check that the keyboard cable is perfectly connected to the X1 logic board connector. The flexible cable must be connected to the connector of the logic board nearest to the board itself, while the possible short connector must be connected so that it ends at pin 31. • Replace the keyboard if necessary. • Replace the two timer boards if necessary.
E12	"ANATOMIC" selection key pressed at start-up	The same as Error E11 above.

9.4 Errors during X-ray exposure

DISPLAY signalling	ANOMALY type	Checks and operations to execute
E20	X-ray relay does not close within a prefixed time	Check that the keyboard cable is perfectly connected to the X1 logic board connector. The flexible cable must be connected to the connector of the logic board nearest to the board itself, while the possible short connector must be connected so that it ends at pin 31. Replace the keyboard if necessary; otherwise replace the two boards of the timer.
E21	X-ray relay does not open within a prefixed time (50 msec)	Serious failure of safety devices. Switch the timer off immediately as there may be X-ray emission. Check that the keyboard cable is perfectly connected to the X1 logic board connector. The flexible cable must be connected to the connector of the logic board nearest to the board itself, while the possible short connector must be connected so that it ends at pin 31. Replace the keyboard if necessary; otherwise replace the two boards of the timer.
E22	The triac controlling X-ray emission does not close within a prefixed time (50 msec)	Check that the keyboard cable is perfectly connected to the X1 logic board connector. The flexible cable must be connected to the connector of the logic board nearest to the board itself, while the possible short connector must be connected so that it ends at pin 31. Replace the keyboard if necessary; otherwise replace the two boards of the timer.
E23	The triac controlling X-ray emission does not open within a prefixed time (50 msec)	No load connected to the board; check the correct and complete insertion of tubehead wires. Check for possible flat cable between power and logic boards not well inserted (connected). If the cable is broken, replace it; otherwise replace the Power and Logic boards.
E24	X-ray button results pressed at the system enabling	Check that the X-ray button is closed and replace it if necessary.
E25	Intervention of hardware safety circuit	The emission has been stopped by the intervention of the hardware safety circuit (backup timer). Emission may start again immediately at start-up, so any maintenance action must be carried out with the tubehead disconnected. Check possible damages to the flexible cable connecting the two boards and replace it if necessary. Switch the system on again; if the anomaly continues, message E02 will be displayed; replace the two timer boards.

9.5 Faults not signalled

9.5.1 The timer does not work

**WARNING:**

THE TWO TIMER BOARDS, CPU AND POWER ARE MATCHED IN THE FACTORY. DO NOT REPLACE ONLY ONE OF THESE BOARDS SINCE THIS COULD AFFECT ON HOW THE SYSTEM FUNCTIONS.

- **The timer switch does not come on**

Line voltage is not present, check the main line switch.

- **The timer switch does come on, but there are no messages on the display**

Check LED H1, on the lower right part of the power board:

1. If LED H1 is on, check that fuse F4 (630mA) is working. If the fuse is burnt, replace it. Otherwise check the flexible cable connecting the power board and the logic board (CPU). Check that it is connected correctly or if there are any broken cables; replace the cable if necessary.
2. If LED H1 does not come on, this means that the main fuse F2 (6.3A, 250V) is disconnected; replace it.

If fuse F4 continues disconnecting, replace the timer.

- **Main fuse F2 continues to disconnect**

This means that there is an anomalous absorption of current, the possible cause of which may be a cable reversal connecting the tubehead or the presence of a short-circuit.

Check that the correct cables are connected to terminals X3 and X4, i.e. the ones with corresponding labels (see paragraph 6.5).

- **Check if there is a short-circuit on the boards**

1. Disconnect the tubehead cable removing the cables marked L2/X3 and N2/X4 from the corresponding X3 and X4 connectors on the power board.
2. If possible, connect a test resistance (680 Ω , 100W) to terminals X3 and X4 (* check the following note).
3. Select an exposure time of about 2s on the timer and emulate more exposures (3 or 4); in these conditions there is no X-ray emission as the tubehead is disconnected.
4. If the fuse melts, there is a short-circuit on the power board, so replace the timer.
5. If the fuse does not melt, check possible marking errors on the tubehead cable, making sure to put the scissors arm in a safety condition by closing it and tying it, so as not to harm people or the arm itself.

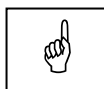
**NOTE (*):**

If you do not have a test resistance, the test may be performed in a similar way, but after each exposure the error message “**E23**” will be displayed. Zero set it by switching the timer on and off again.

- **Check that cables are labelled correctly**

1. Close the two parts of the scissors arm and tie them together.
2. Lift the protection cap of the sliding connector until you see the insertion slot of the elastic ring.
3. Holding the tubehead with one hand, remove the safety ring.
4. Remove the tubehead gently, rotating it if necessary.
5. Using a digital multimeter, read the resistance values with scale bottom of about 1k Ω (or lower), check that the cable marked L2/X3 is connected to the central terminal of the sliding contact (male) placed in the arm; this is tested if the multimeter reads a very low resistance value (near zero Ω); if you measure a high value, generally shown as ∞ , this means an exchange of labels; so you must connect cable L2/X3 to X4 and vice versa, or, exchange the two labels and connect as usual.
6. Check that the two cables are not in short circuit by reading the resistance which must be infinite between the two cable terminals on the same side and between the terminals and the ground cable.

- **Faulty tubehead**

If previous tests give positive results (correctness of cable marking and absence of short-circuits in the tubehead cable), a possible cause is a short circuit inside the tubehead. Replace the tubehead using the procedure described in the provided section of the manual.

10. REPLACING PARTS

10.1 Replacing the tubehead



WARNING:

Before proceeding with replacing the tubehead, close and tie the two sections of the scissors arm together.

Failure to do this will not only cause serious problems when assembling the system but may also harm both the installer and the arm itself.

1. Remove the safety screw and lift the protection cap of the sliding connector until you can see the insertion slot of the elastic safety ring. In this way the protection cap is lifted leaving the safety ring in view.
2. Holding the tubehead in one hand, remove the safety ring.
3. Remove the tubehead gently, rotating it if necessary.
4. Assemble the new tubehead proceeding then with the operations already described for tubehead assembly (paragraph 6.3).



NOTE:

After replacing the tubehead it may be necessary to reset the counter of executed exposures (see paragraph 8.1, parameter "**P16**").

The system is certified to operate with two tubeheads models mounting different X-ray tubes. When replacing the tubehead check that the pre-heating time in set-up (P03) is configured to the same value reported in the tubehead label.

10.2 Replacement timer boards

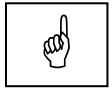
**NOTE:**

The timer boards are matched in the factory and therefore must be replaced as a couple.

To access the boards refer to the set-up procedure.

10.3 Replacing the keyboard

Replacing the keyboard consists in replacing the adhesive membrane: remove the timer covering panel, remove the old membrane carefully after disconnecting the cables and clean the surface where the membrane was attached.

**NOTE:**

Do not use solvent, but only alcohol.

Attach the new membrane restoring connections.

10.4 Replacing the scissors arm

Follow instructions in the spare arm kit.

11. SCHEMATICS AND DRAWINGS

1. ENDOS ACP – General connection diagram
2. ENDOS ACP – General connection diagram for mobile
3. ENDOS AC – General connection diagram
4. ENDOS AC – General connection diagram for mobile
5. Power board layout
6. Logic board layout

THIS PAGE IS INTENTIONALLY LEFT BLANK

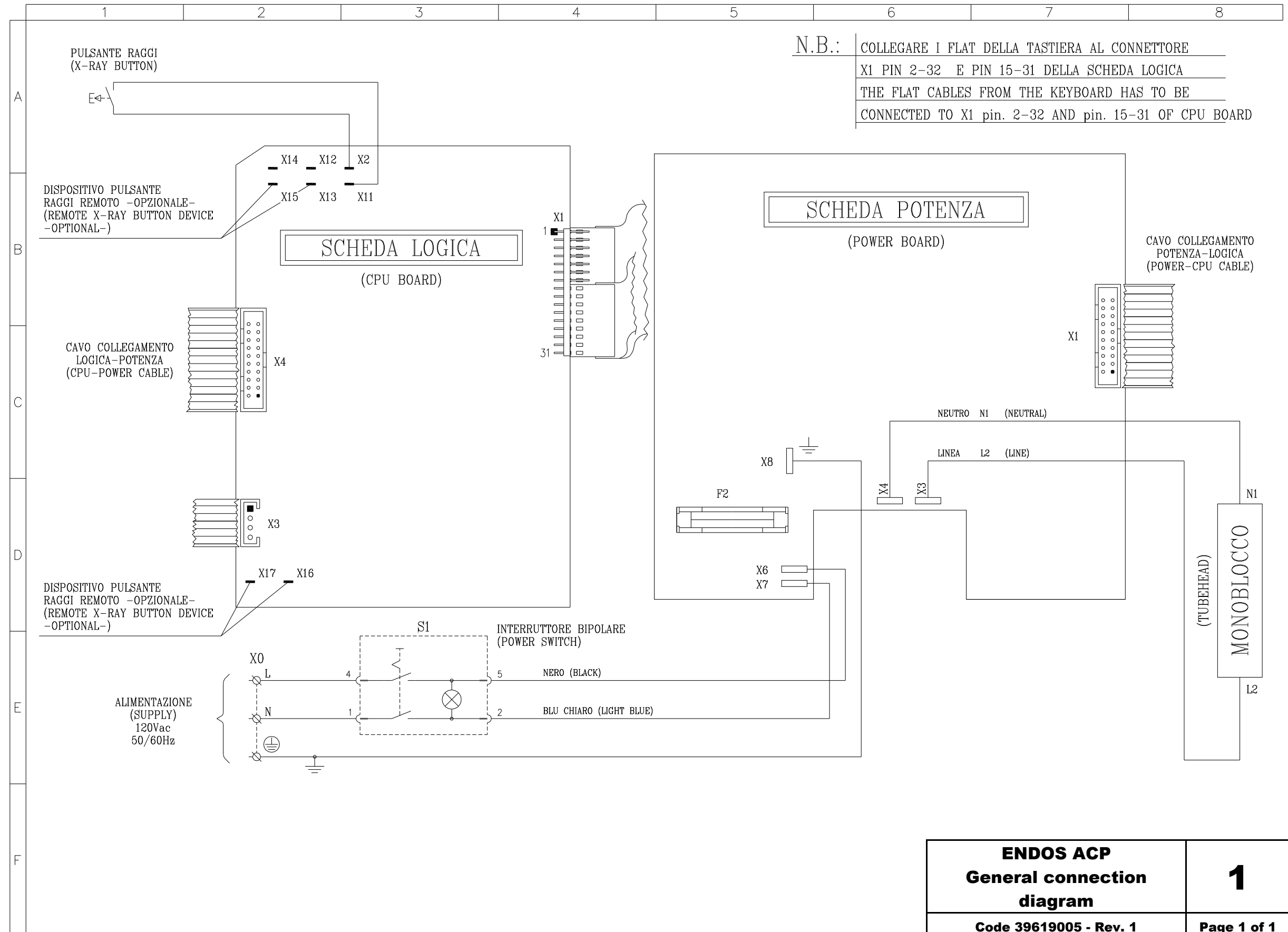

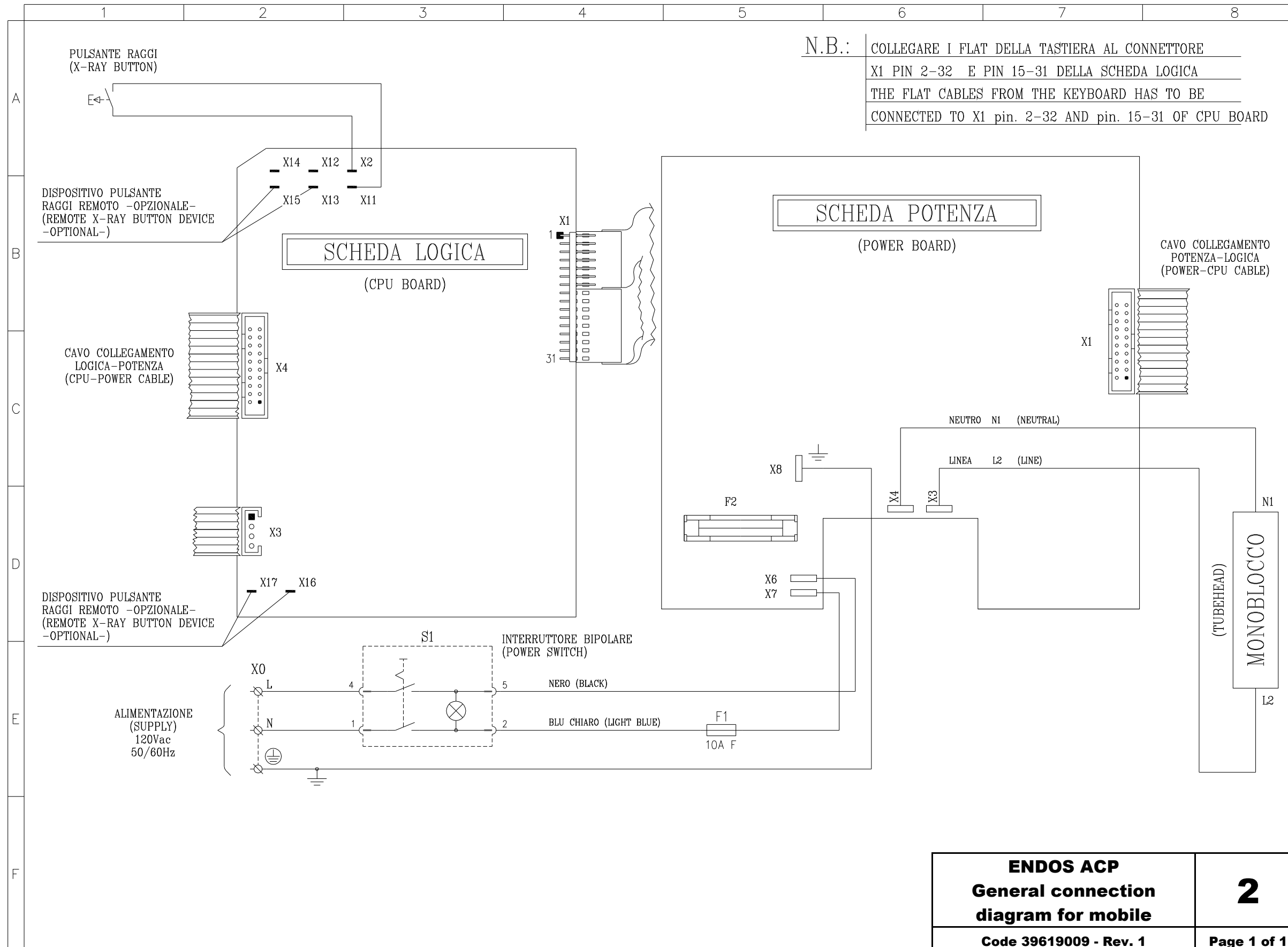

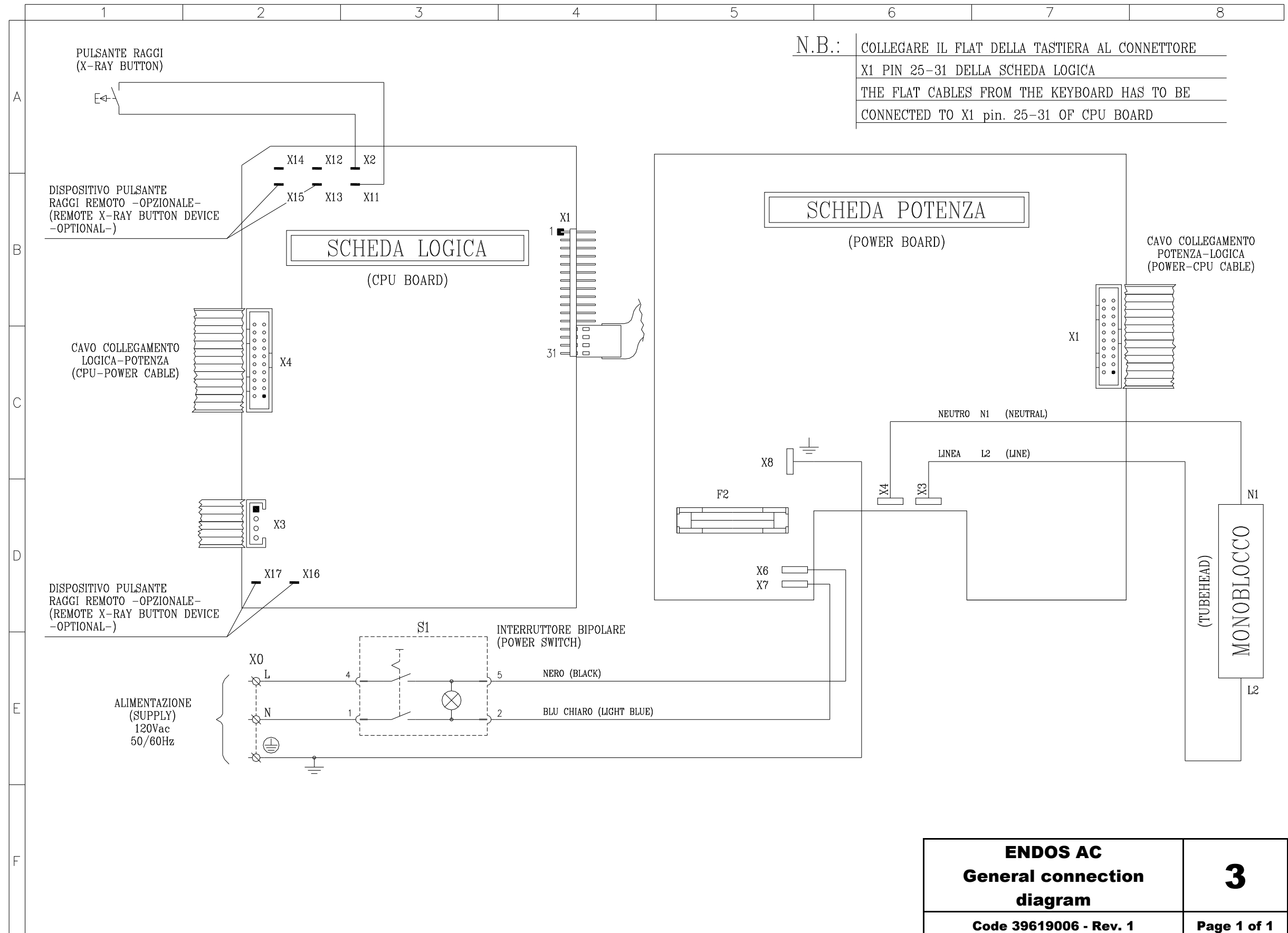

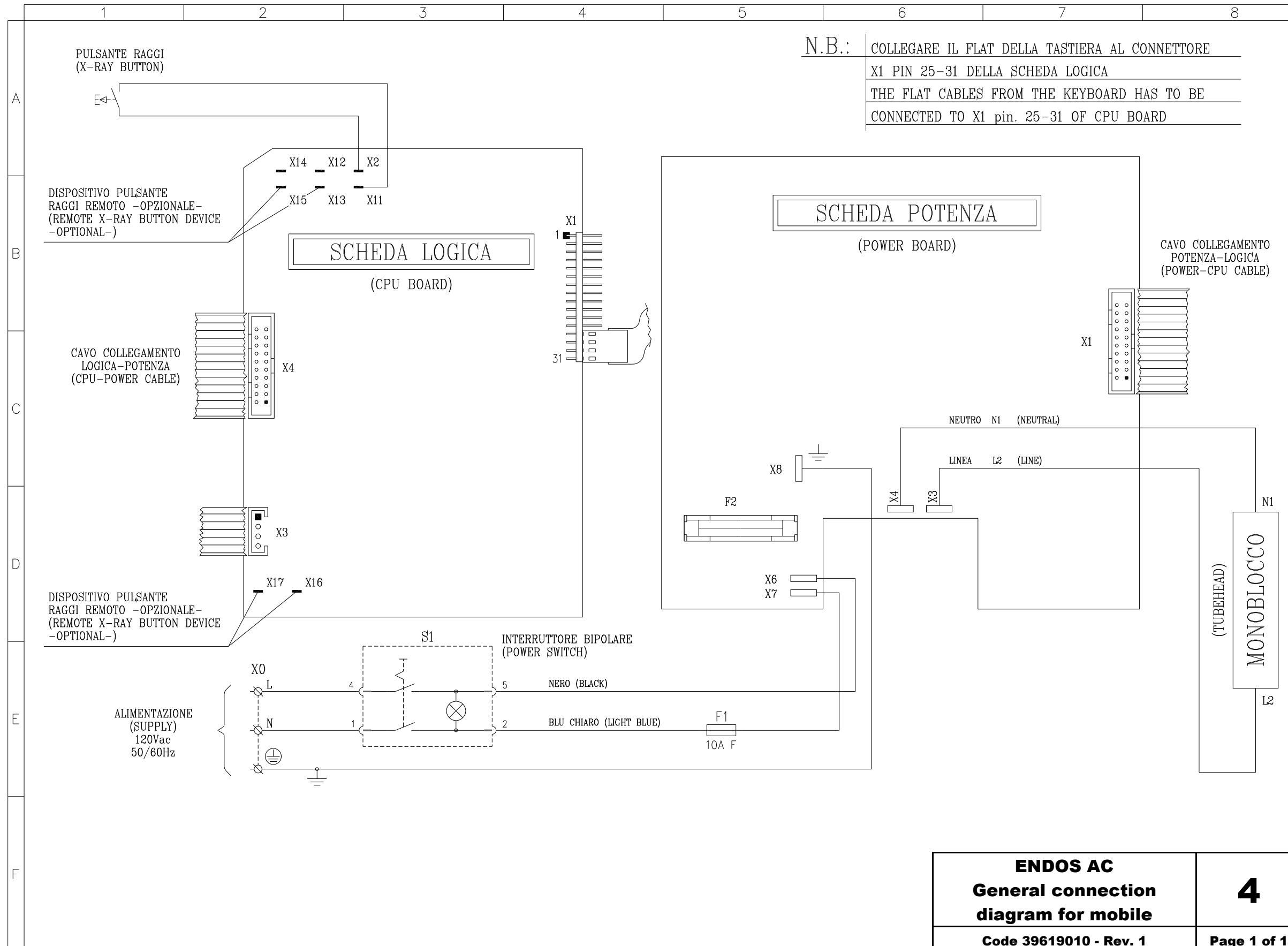

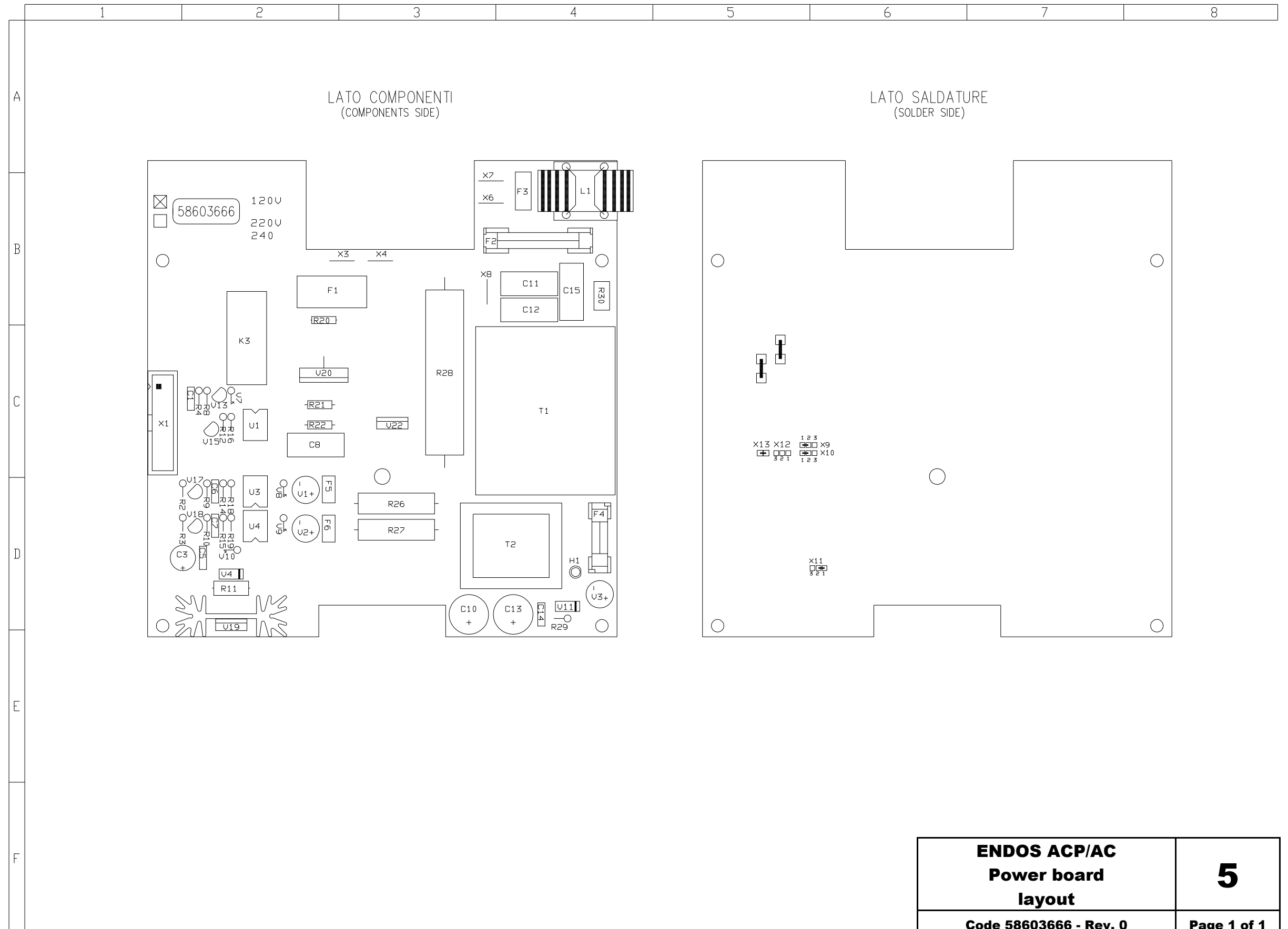

ENDOS ACP/AC Power board layout	5
Code 58603666 - Rev. 0	Page 1 of 1

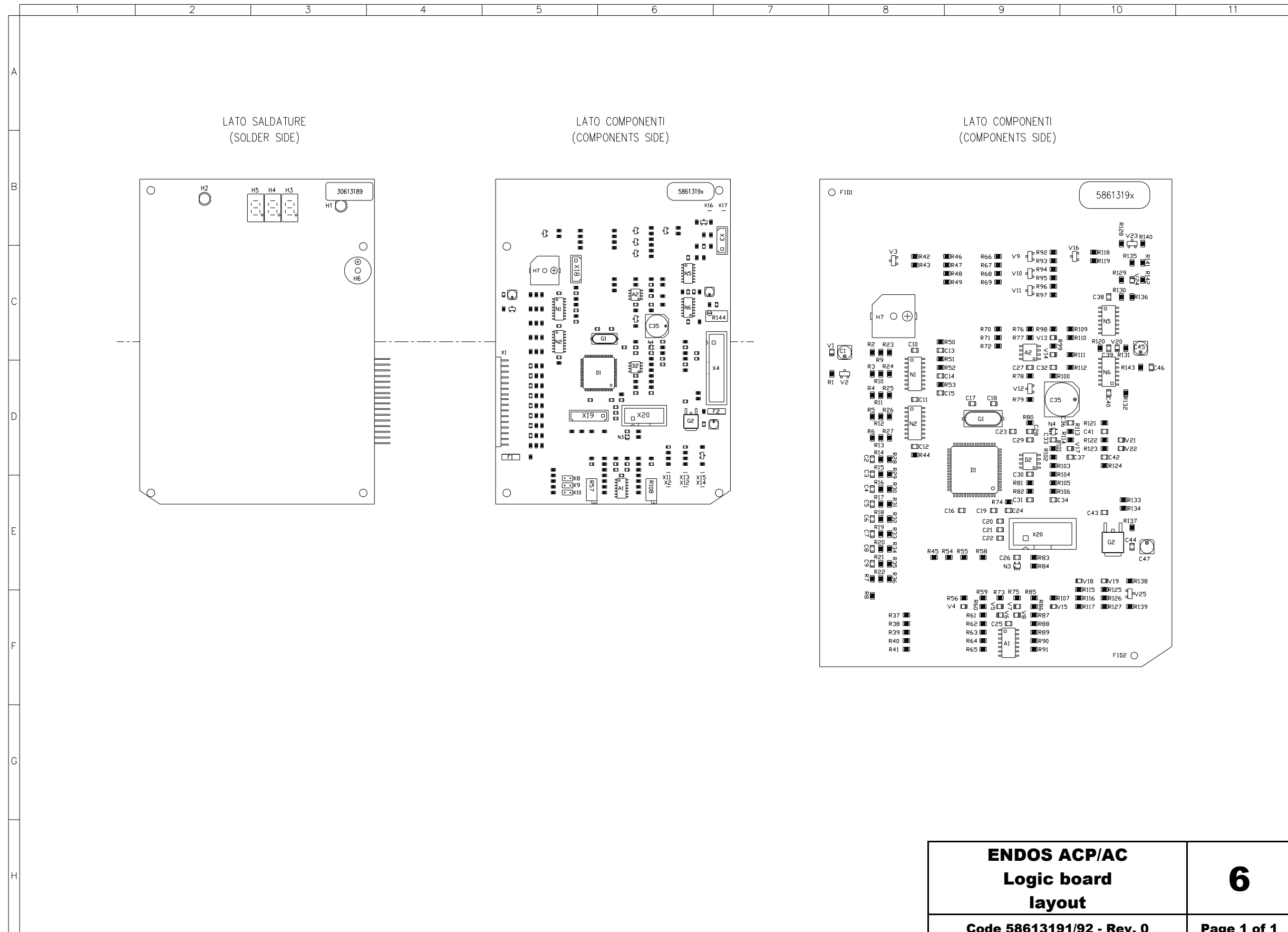

ENDOS ACP/AC Logic board layout	6
Code 58613191/92 - Rev. 0	Page 1 of 1

12. SPARE PARTS

- 1 – TIMER: ENDOS AC – ENDOS ACP**
- 2 – EXTENSION ARM / SCISSOR ARM**
- 3 – MOBILE STAND**
- 4 – TUBEHEAD**
- 5 – OPTION**

1 – TIMER: ENDOS AC – ENDOS ACP

Ref.	VSM code	Description	Note
1	6661301800	Frictioning mechanism assy	
2	6261308800	Kit PCB ENDOS AC	
	6261308900	Kit PCB ENDOS ACP	
3	6661303800	X-ray button holder	
4	6261303300	X-ray push button	
5	6261305100	Flat cable X1-X4	
6	4291415900	ON/OFF switch	
7	5461305400	Keyboard for ENDOS AC	
	5461304100	Keyboard for ENDOS ACP	
	5461305800	Remote Timer front cover	
8	6661310000	ENDOS AC front cover complete	
	6661310100	ENDOS ACP front cover complete	
	6661310300	Remote Timer front cover complete	
F2	2300974400	Fuse 10A F 6.3x32	Mounted on Power PCB
F4	2300938000	Fuse 630mA T 5x20	Mounted on Power PCB
F1	2300974400	Fuse 10A F 6.3x32	For mobile version
-	4560311800	Fuse holder	For mobile version
	4560311900	Cap for fuse holder	

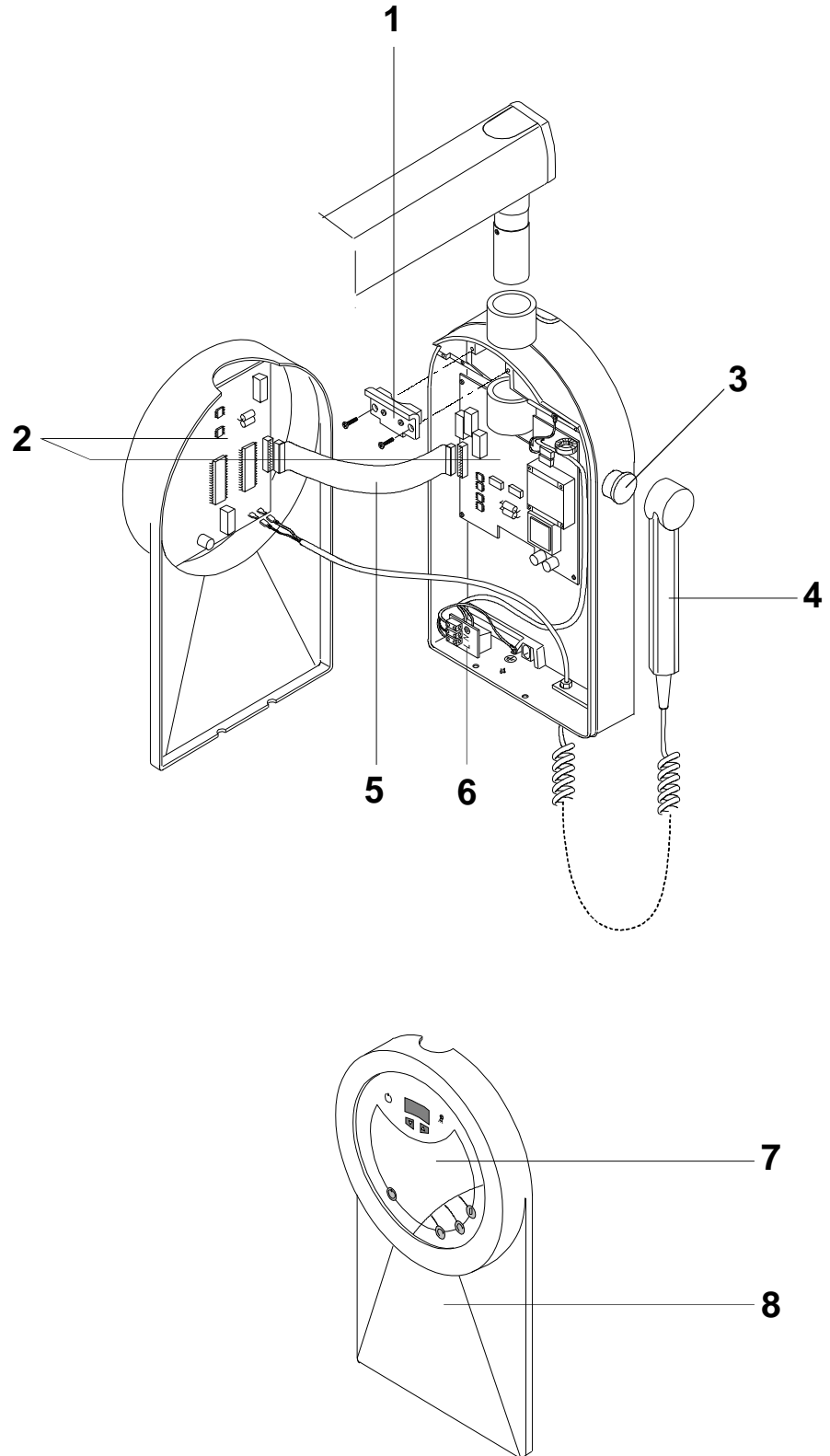

2 – EXTENSION ARM / SCISSOR ARM

Ref.	VSM code	Description	Note
1	6661210000	Scissor arm joint covers kit (DX + SX)	
2	8161200602	Scissor arm complete	
3	6661210400	Extension arm end-covers kit	
4	5160402800	Seeger	
5	5461205002	Sliding cover of seeger	
6	6659210100	Extension arm frictioning mechanism	for arm S/N ≥ 11120813
	6661210200	Extension arm frictioning mechanism	for arm S/N < 11120813
7	5160249500	Busher Ø 28 mm	
8	8161200302	Extension arm 30 cm	
	8161200502	Extension arm 60 cm	
	8161200402	Extension arm 80 cm	

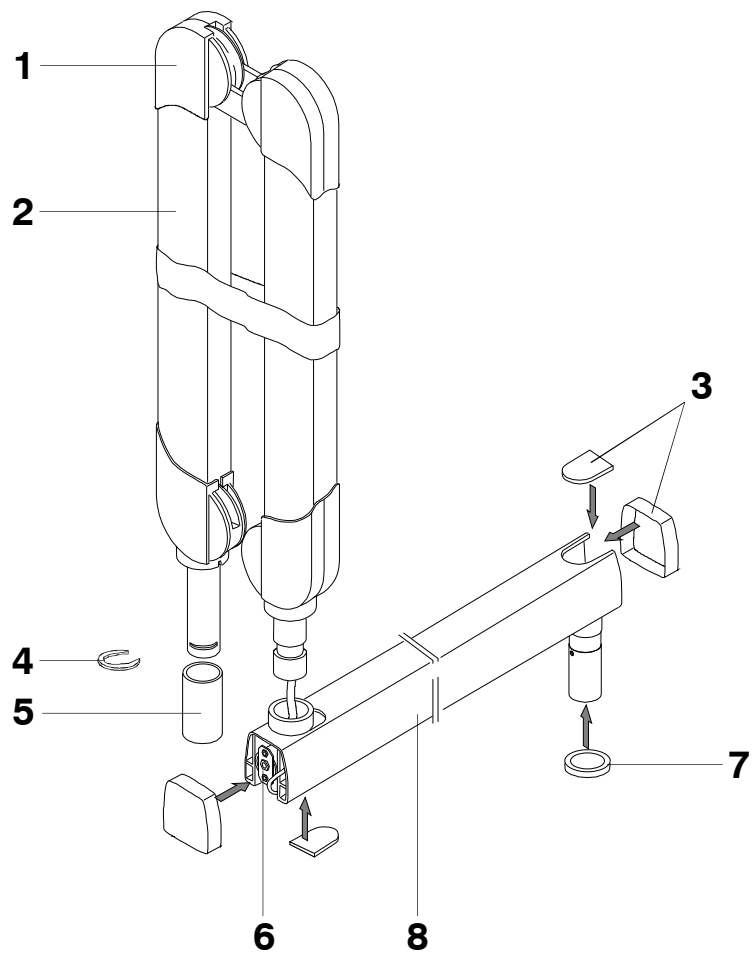

3 – MOBILE STAND

Ref.	VSM code	Description	Note
1	8160120000	Mobile stand complete	
2	4890310400	Wheel with brake 80x24	
	4890307000	Wheel 80x24	
3	6661305600	Mobile stand spacer	
4	5261304700	Timer fixing plate	

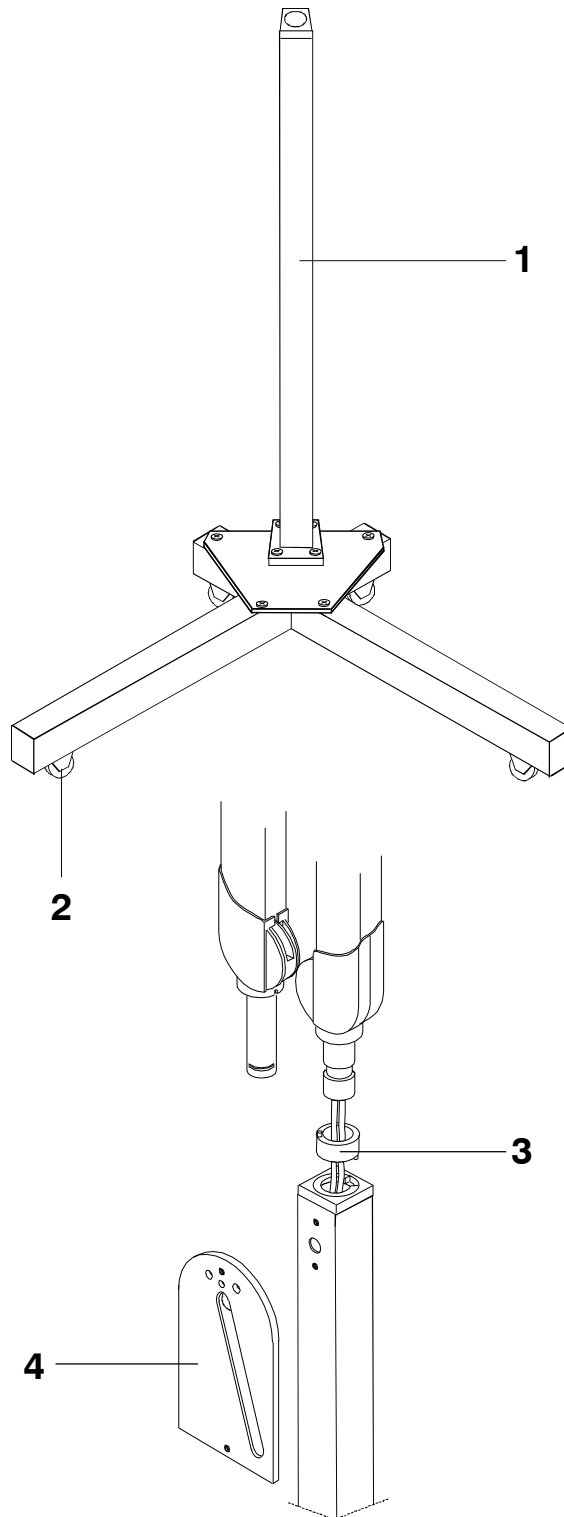

4 – TUBEHEAD

Ref.	VSM code	Description	Note
1	5160402800	Seeger	
2	6160204400	Grounding clip assy	
3	5461205002	Sliding cover of seeger	
4	6260439600	Sliding connector (male)	
5	6661408500	Tubehead cover kit (without label)	
6	5160423800	Angle indicator	
7	5460420803	Tubehead lateral cover	
8	7260474502	Tubehead support	
9	5160401800	Aluminium filter 1mm	
10	8461406602	Tubehead complete assembly (CEI tube)	
	8461406612	Tubehead complete assembly (KAILONG tube)	

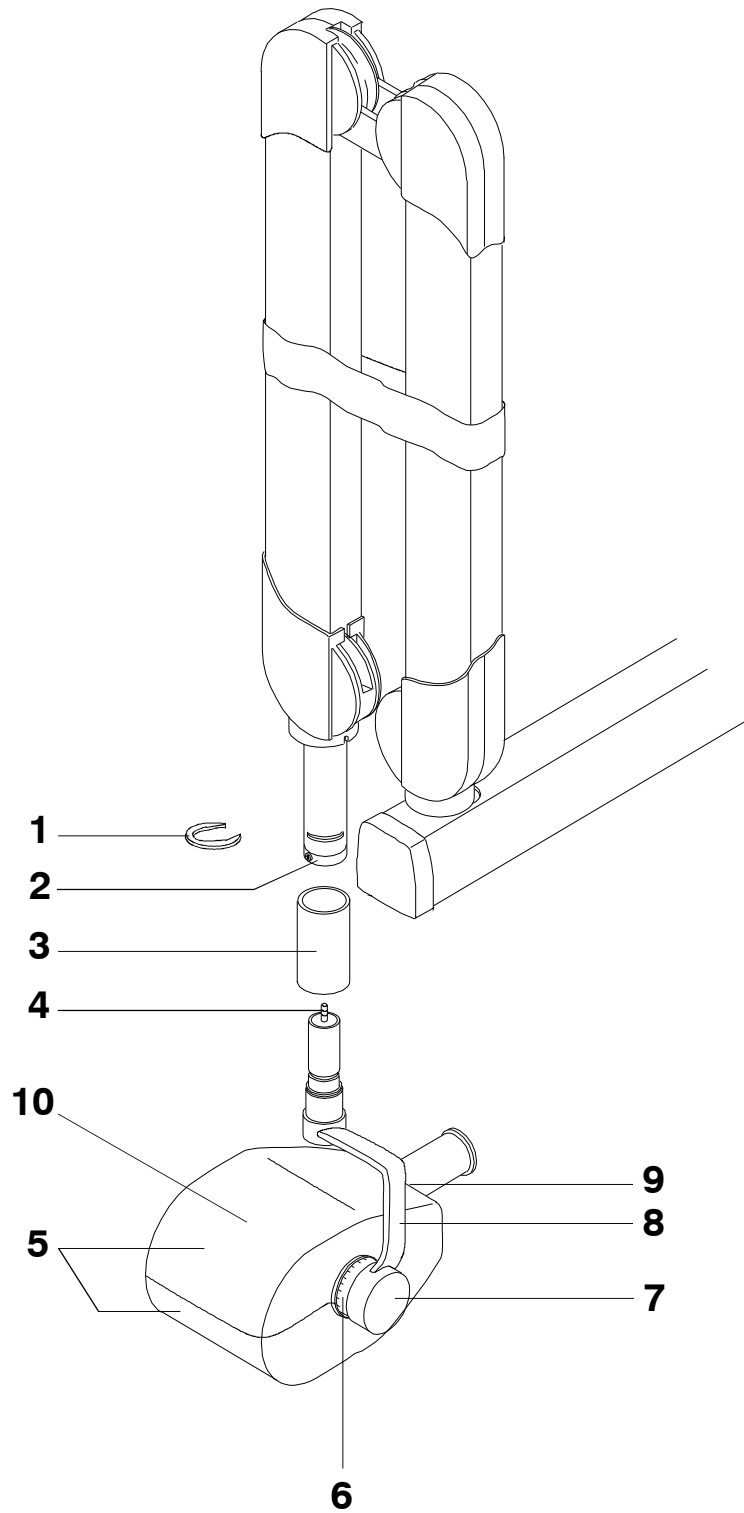

6 – OPTION

Ref.	VSM code	Description	Note
1	6661309500	Remote X-ray button with light indicators	
2	8161301002	Remote Timer kit	
3	6160462003	Rectangular beam limiting device 45x35mm	
4	6161405000	Extension cone for SFD 300mm	
5	5661307900	Counterplate	
6	6661209900	Allen wrenches kit	

THIS PAGE IS INTENTIONALLY LEFT BLANK

THIS PAGE IS INTENTIONALLY LEFT BLANK

13. FIXING TEMPLATES

The system is equipped with a set of templates, composed of the following elements:

Code	Description
39619100	Template for standard and remote version

THIS PAGE IS INTENTIONALLY LEFT BLANK



Cod. 6961902103_Rev.7

CE 0051

Dent-X Corporation USA
250 Clearbrook Road
Elmsford, New York 10523
Phone: (914) 592-6100
Fax: (914) 592-6769